

Semiconductor Flow Equipment

Vacuum Tubes & Fittings



NEUMO | HPT | EGMO

NEUMO Ehrenberg Group

SciMax[®] - Vacuum Components

EGMO develops, manufactures, designs markets, and sells high-quality stainless-steel Vacuum components for the semiconductor industry, gas delivery systems, and water purification.

EGMO offers a wide product range that includes:

- ✓ **Machined part** - KF & ISO connections, bellows
- ✓ **Tubular fittings** - Elbows, tees, reducers
- ✓ **Complementary products** - Clamp, centering rings
- ✓ **Customized products**
- ✓ **Tubes**

About EGMO

EGMO, a member of the NEUMO Ehrenberg Group, is a worldwide leading manufacturer of high quality stainless steel products for the semiconductor, biopharmaceutical and food industries. Founded in 1965, EGMO brings its customers decades of experience in the development and production of an innovative and extensive range of tubes, fittings, valves, vessels and other special components. EGMO is ISO 9001:2015, CE, ASME & CRN certified and its products also meet the following standards: TUV, 3A, DIN, ISO, CE, SMS, BS (RJT).



About HPT

High Purity Technology (HPT), located in the Hudson River Valley of New York, has supplied Semiconductor OEMs and End users with tubing and fittings cleaned for ultra-high purity systems and related applications since 1983. HPT has built its reputation as the leader in ultra-high purity products and services through experience, commitment to quality, and a strong dedication to customer service and support.

As a member of the Neumo Ehrenberg Group, HPT is the primary distributor of the SciMax[®] brand of UHP tubing and fittings throughout the Americas. HPT's extensive distribution network and stocking programs provide the ability to meet your delivery requirements - keeping your projects on schedule.

NEUMO Ehrenberg Group

The NEUMO Ehrenberg Group, a diversified multi-national organization headquartered in Germany, was founded by Senator Henry Ehrenberg in 1947. The know-how, experience, and impressive track record of its companies, NEUMO, HPT and EGMO, have been earned over four decades. Today, the group is a leading manufacturer of worldwide stainless-steel process fittings and components. The Group's worldwide distribution network supports major multinational accounts.



| www.egmo.co.il |

Index

Glossary.....	4
SMV - SCiMax Vacuum Line	
Material Specification for SciMax SMV Tubes and Fittings.....	6
KF Flanges & Fittings.....	8
KF Weld Flanges & Fittings.....	13
ISO Flanges.....	15
ISO Flanged Fittings.....	20
ISO Weld Fittings.....	21
Vacuum - Electro-polished Tubes & Fittings.....	27
MTR - Material Test Report.....	35



Industry Terms Glossary

Term	Acronym	Definition
A American Society of Mechanical Engineers	ASME	Creates consensus standards for Mechanical Engineering.
American Society for the Testing & Materials	ASTM	Creates consensus standards for material quality and material quality testing methods.
ASME- B46.1	B46.1	The standard defines surface texture and its constituents: roughness, waviness, and lay. It also defines parameters for specifying surface texture.
ASME - B31.3	B31.3	American National Standard that covers piping typically found in pharmaceutical, semiconductor, cryogenic plants, and related processing plants and terminals. B31.3 applies mostly to inspection, examination, and testing of systems.
ASTM A 262 Practice E	A 262	Is a Strauss Test that requires the samples to be boiled in a Cu-Copper Sulfate mixture for 15 hours and then bent 180 degrees over an equal diameter bend. This test uses visual inspection of the bent surface to determine a pass or fail.
ASTM-A 269	A 269	Specification titled "Seamless and Welded Austenitic Stainless-Steel Tubing for General Service". It covers a variety of grades of austenitic stainless steel tubing.
ASTM-A 270	A 270	Is the standard specification for the welded seamless, and heavily cold-worked welded austenitic and ferritic stainless steel sanitary tubing. It includes the stainless-steel tube types in seamless and welded.
ASTM A312	A 312	is a specification for seamless and welded austenitic stainless steel pipes that perform well in high temperature and corrosive environments
ASTM A403	A 403	Stainless Steel Pipe Fittings refers to the material of forged and rolled austenitic stainless fittings for pressure pipes
ASTM A 778	A 778	It covers welded not annealed stainless steel pipe intended for low to moderate temperatures and corrosive service where heat treatment is not required for corrosion resistance.
ASTM A1016	A1016	Standard Specification for General Requirements for Ferritic Alloy Steel, Austenitic Alloy Steel, and Stainless Steel Tubes.
B Bright Annealed	BA	Heat treatment process in a vacuum is used to alter metals' mechanical and physical properties to reduce hardness, increase ductility (flexibility), eliminate internal stresses, and improve corrosion resistance.
Butt Weld		Is one of the simplest and most versatile types of weld joint designs. The joint is formed by placing two pieces of metal end-to-end and then welding along the joint.
C CFOS		Clean for Oxygen Service.
CGA	G-4.1	Compressed Gas Association (CGA) G4.1 describes the cleaning methods and requirements for equipment used in the production, storage, distribution, and use of liquid and gaseous oxygen to reduce the risk of fire, explosion, or promotion of combustion.
E Eddy Current Testing		In the eddy-current testing of tubes, an inspector will run a probe through the length of a tube to identify tiny defects. It can also help to identify defects on the surface of materials, with the use of pulsed eddy current testing equipment.
EN 10204 3.1		The EN 10204 Type 3.1 Inspection Certificate are actual test results from the material in the lot from which the steel products have been supplied.
I ISO2681	ISO2681	Specification for standard USA tube sizes.

Term	Acronym	Definition
K "Klein Flansche" (KF) or Quick Flange (QF)	KF	Vacuum flanges are an ISO standard quick-release flange. These flanges may also be referred to as NW or DN flanges. Adopted by ISO, DIN, and Pneurop, the KF flange features a chamfered back surface that is set against an elastomeric O-ring.
N NW	NW	NW Vacuum Flanges and Fittings are quick-release and are great in rough vacuum to high vacuum applications.
P PMI		Positive Material Identification is a fast and non-destructive testing (NDT) method for verifying the chemical composition of metals and alloys.
Q QF		See KF above.
R Roughness Average	Ra	An expression of measured surface roughness or texture, typically, of a polished or machined metal surface. The arithmetic average value of the departure (peaks and valleys) of a surface profile from the center line throughout the sampling length, is generally expressed in microinch(μ in) or micro-meter(μ m) units and measured with profilometers.
Rockwell scale		The Rockwell scale is a hardness scale based on the indentation hardness of a material.
Rockwell B		The B-scale is used for softer materials (such as aluminum, brass, and softer steel). It employs a hardened steel ball as the indenter and a 100kg weight to obtain a value expressed as "HRB."
S Seamless Tube	SL	Tube produced from a solid billet that is heated and rotated under pressure. This rotating pressure creates a hole in the middle of the billet, which is then formed into a tube by a mandrel.
SMV		SciMax Vacuum Line
SM10		SciMax Vacuum Tubes and Fittings products.
Strauss test		Is a method for detecting the susceptibility of austenitic stainless steels to intergranular attack
Surface Finish		Are all interior surface finishes accessible and in-accessible, that directly or indirectly are in contact with the fluid (gases/liquids).
T Tubing Dimensions		O.D. - outside diameter I.D. - inside diameter Wall thickness or gauge. All tube dimensions are specific; pipe dimensions are nominal. Specific means actual measurements in inches. Nominal means the theoretical or stated value of a dimension.
U Ultra-high vacuum	UHV	Ultra-high vacuum
W Welded Tube	W	Welded stainless steel tube is produced through roll-forming strips or sheets of stainless steel into a tube Description and then welding the seam longitudinally.

SMV - SCiMax Vacuum Line

Material Specification for SciMax SMV Tubes and Fittings

Product	Welded Austenitic Stainless-Steel Tubing									
Specifications	ASTM- 312, ASTM-774, ASTM-A403, A269, A270, A778									
	Referenced documents: ASTM A1016, ASTM E112, ASTM A262 Practice-E.									
Dimensional Specification & Tolerances	Tubing	OD Size:			Wall Thickness:					
		½"			0.049"					
		¾" through 3"			0.065"					
		4" and 6"			0.083"					
		8"			0.120"					
		10"			0.125"					
	12.75" (NPS12, OD12.75")			0.156" (Sch. 5)						
	Tolerances: Acc. to ASTM A269, A270 Supplement 2									
	Fittings	Size	½" to 10", 12.75" (NPS12, OD12¾")							
		KF	Bored Flange, Long Flange, Short Flange, Blind Flange, Wingnut and Toggle Clamp, Over pressure ring, Bellow							
		ISO	Bored Flange, Half Nipple, Blind Flange, Double Claw Clamp [AI] , Bellow							
		Butt-weld	Elbow, TEE, Reduce TEE, Reducer and End Cap							
	Center Ring Assembly:	KF	S.Steel centering ring with Viton O-ring and Over pressure ring (Kalrez and Chemraz - Upon Request)							
		ISO	S.Steel centering ring with Viton O-ring and Over pressure ring (Kalrez and Chemraz - Upon Request)							
Chemical Composition 304 (304L)	%	C	Cr	Mn	Mo	Ni	P	Si	S	
	min		18		-	8.0				
	max	0.070 (0.030)	20.0	2.0		12.0	0.045	1.00	0.030	
Chemical Composition 316L	%	C	Cr	Mn	Mo	Ni	P	Si	S	
	min		16		2.0	10.0				
	max	0.030	18.0	2.0	3.0	14.0	0.045	1.00	0.030	
Surface Finish	BA - Bright annealed - up to 4"									
	AP - Annealed & Pickled - 6" up to 12.75" (NPS12, OD12.75")									
	Acceptance Criteria Acc. to ASTM A270 Supplement 2									
Tube Length	Nominal Lengths				FT.		MT.			
					19-20		5.8-6.1			
Mechanical Tests	Hardness Test - 90 [Rockwell B] Max ASTM A270 S2 (§ S2.3)									
Testing & Inspection	Visual inspection									
	Dimensional measurement									
	Helium-leak testing Where needed									
Plain Ends	All tubing shall be Square ends ready for welding, with no chips, burrs or other imperfections of the welding edge, that can influence the welding results.									
Cleaning	Cleaned for O2 service - All tubing surfaces shall be clean and free of oils, grease, particulates, grinding compounds, dust, rising residuals or electrolytes, and stains.									
Marking and Labeling	Tubes and Fittings shall be permanently marked or marked on the exterior of the bags with the following information.									
	Brand Name	Size O.D	Wall Thick.	Material Grade	Lot Number	Heat Number				
Packing	All products will be capped and packed with polyethylene sleeves and ready to ship									
Certification	Inspection documents certification to be according to DIN EN10204 3.1. Full Material Test Report (MTR) to be provided with the material. standard.									

How to order

Tubing:

S **M** **V** - **T** **U** **B** **E** - **3** **0** **4** **L** - **1** **.** **0** X **0** **.** **0** **6** **5**

Product Line Description Material O.D. Size Inch Wall Thickness Inch

Product Line	Description	Material	O.D. Size Inch	Wall Thickness Inch
SMV - SciMax Vacuum	Tube	304L	0.5	0.049
		316L	0.75	0.065
			1.0	0.065
			1.5	0.065
			2.0	0.065
			2.5	0.065
			3.0	0.065
			4.0	0.083
			6.0	0.083
			8.0	0.120
			10.0	0.125
			12.75	0.156

SMV Tubes Data

O.D size Inch	304L		316L		Surface Finishing	Wall Thickness
	Name	Catalog#	Name	Catalog#		
½"	SMV-TUBE-304L-0.5X0.049	571-00022	*	*	Bright annealed	0.049
¾"	SMV-TUBE-304L-75X0.065	571-00032	*	*	Bright annealed	0.065
1.0"	SMV-TUBE-304L-1.0X0.065	571-00004	SMV-TUBE-316L-1.0X0.065	571-00043	Bright annealed	0.065
1½"	SMV-TUBE-304L-1.5X0.065	571-00025	SMV-TUBE-316L-1.5X0.065	571-00044	Bright annealed	0.065
2.0"	SMV-TUBE-304L-2.0X0.065	571-00026	SMV-TUBE-316L-2.0X0.065	571-00045	Bright annealed	0.065
2½"	SMV-TUBE-304L-2.5X0.065	571-00027	*	*	Bright annealed	0.065
3.0"	SMV-TUBE-304L-3.0X0.065	571-00028	SMV-TUBE-316L-3.0X0.065	571-00046	Bright annealed	0.065
4.0"	SMV-TUBE-304L-4.0X0.083	571-00029	SMV-TUBE-316L-4.0X0.083	571-00047	Bright annealed	0.083
6.0"	SMV-TUBE-304L-6.0X0.083	571-00030	SMV-TUBE-316L-6.0X0.083	571-00042	Annealed & Pickled	0.083
8.0"	SMV-TUBE-304L-8.0X0.120	571-00001	*	*	Annealed & Pickled	0.120
10.0" **	SMV-TUBE-304L-10.0X0.125	571-00002	*	*	Annealed & Pickled	0.125
12.75" ***	SMV-Tube-304L-12.75X0.156	571-00048	*	*	Annealed & Pickled	0.156

* Upon Request

** ASTM A-778

*** ASTM A-312

KF Flanges & Fittings

General

KF flange fittings are simple and flexible O - ring vacuum couplings similar to the ISO certified KF (or Klein Flange), and QF (Quick Flange) flanges. EGMO KF flanges are compatible with vacuum sealing flanges from major vacuum manufacturers; our KF fittings catalogue indicates the tube diameters in inches. An assembly consists of two identical flanges, a clamp, and a centering ring which aligns the flanges and prevents the O - ring from collapsing. The Wingnut clamp typical for KF flanges requires no tools for assembly. The system is ideal for small diameter tubing requiring frequent reassembly. KF flange fittings work in rough vacuum conditions and standard High Vacuum (1×10^{-9} Torr) chambers.

The elastomeric O - ring limits the temperature range and ultimate vacuum of the assembly.

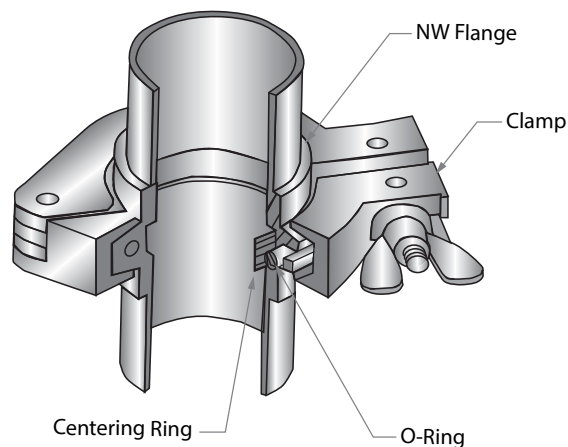

Specifications

The EGMO KF flange fittings were designed according to ISO 2681 specifications for standard USA tube sizes from .5 to 2.00 inches. KF flange fittings can be used in a variety of applications from atmospheric pressure to high vacuum. The KF flange fittings are compatible with other ISO - KF - QF designed flanges.

The KF flange fittings are manufactured from 304, 304L and include an aluminum clamp to facilitate frequent disassembly without tools.

KF flange fittings can be used up to 150 °C when using a UHV Viton O - ring seal which extends in vacuum applications up to 10^{-8} Torr.

EGMO also offers 316L stainless steel KF flange fittings for rugged corrosion resistance in semiconductor processing, with excellent repeatability in high vacuum applications.

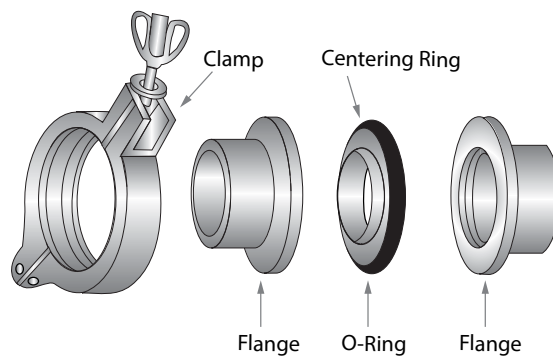

Dimensions

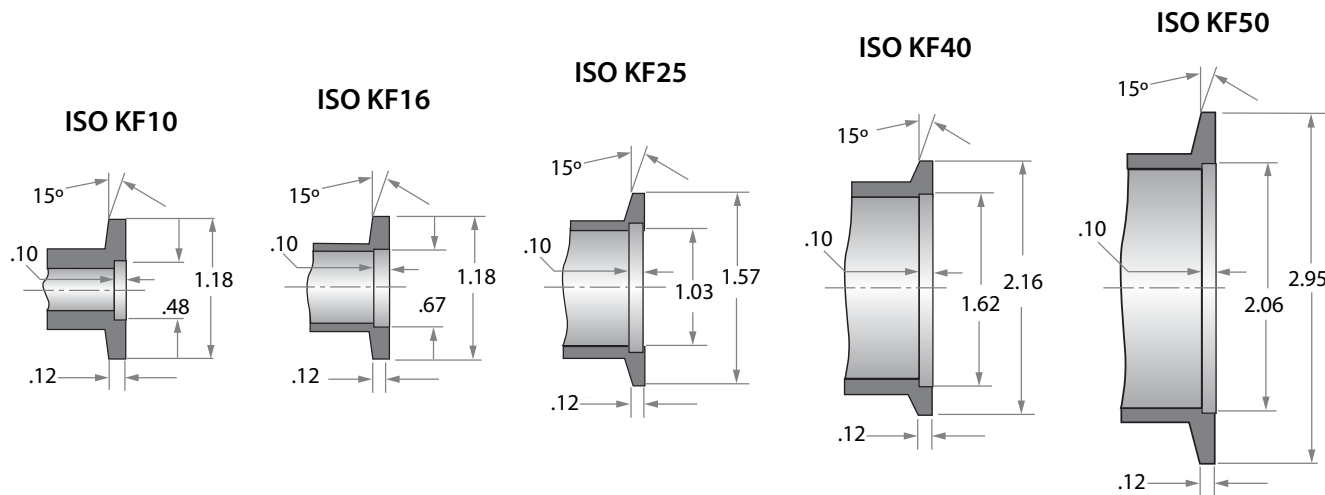

How to order

KF Fittings:

S **M** **V** - **3** **0** **4** **L** - **C** **R** **A** - **K** **F** **2** **5** - **1** **.** **0**
 Product Line Material Description Type O.D. Size Inch

Product line	Material	Description	Type	O.D. Size Inch	
SMV - SciMax Vacuum	304	BOF - Board Flange	KF10	0.500	
	304L	BLF - Blind Flange	KF16	0.750	
	316L	SWF - Short Weld Flange	KF25	1.000	
	ALU - Aluminium*		LWF - Long Weld Flange	KF40	1.500
			CRA - Centering Ring Assembly	KF50	2.000
			OPR - OverPressure ring		
		FB - Flex Bellow			

* Aluminum option can be used only for OPR

KF Bored Flanges

O.D. Size inch	A inch	B inch	C inch	Type	304*		316L	
					Name	Catalog #	Name	Catalog #
½"	0.510	0.451	0.20	KF-10	SMV-304-BOF-KF10-0.5	561-00011	SMV-316L-BOF-KF10-0.5	510-00197
¾"	0.760	0.670	0.17	KF-16	SMV-304-BOF-KF16-0.75	561-00047	SMV-316L-BOF-KF16-0.75	510-00198
1"	1.010	0.938	0.19	KF-25	SMV-304-BOF-KF25-1.0	561-00052	SMV-316L-BOF-KF25-1.0	510-00093
1½"	1.510	1.438	0.20	KF-40	SMV-304-BOF-KF40-1.5	561-00027	SMV-316L-BOF-KF40-1.5	510-00012
2"	2.010	1.938	0.20	KF-50	SMV-304-BOF-KF50-2.0	561-00033	SMV-316L-BOF-KF50-2.0	510-00038

* 304L available upon request

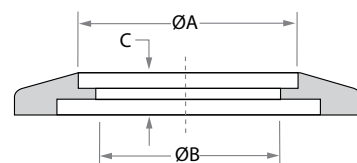

KF Blind Flanges

O.D. Size inch	A inch	Type	304*		316L	
			Name	Catalog #	Name	Catalog #
½"	1.180	KF-10	SMV-304-BLF-KF10-0.5	561-00001	SMV-316L-BLF-KF10-0.5	510-00193
¾"	1.180	KF-16	SMV-304-BLF-KF16-0.75	561-00006	SMV-316L-BLF-KF16-0.75	510-00194
1"	1.575	KF-25	SMV-304-BLF-KF25-1.0	561-00015	SMV-316L-BLF-KF25-1.0	561-00016
1½"	2.160	KF-40	SMV-304-BLF-KF40-1.5	561-00021	SMV-316L-BLF-KF40-1.5	510-00143
2"	2.950	KF-50	SMV-304-BLF-KF50-2.0	561-00028	SMV-316L-BLF-KF50-2.0	510-00144

* 304L available upon request

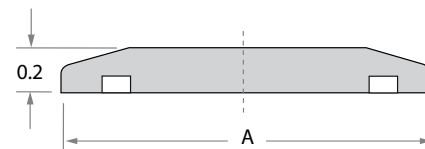

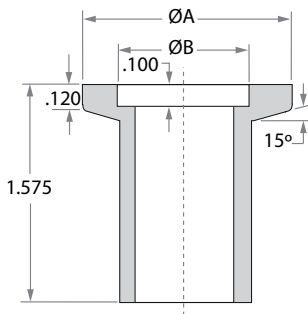

KF Long Butt Weld Flanges

O.D. Size inch	A inch	B inch	Type	304*		316L	
				Name	Catalog #	Name	Catalog #
½"	1.180	0.480	KF-10	SMV-304-LWF-KF10-0.5	561-00002	SMV-316L-LWF-KF10-0.5	510-00202
¾"	1.180	0.680	KF-16	SMV-304-LWF-KF16-0.75	561-00054	SMV-316L-LWF-KF16-0.75	510-00203
1"	1.575	1.031	KF-25	SMV-304-LWF-KF25-1.0	561-00017	SMV-316L-LWF-KF25-1.0	510-00140
1½"	2.160	1.620	KF-40	SMV-304-LWF-KF40-1.5	561-00023	SMV-316L-LWF-KF40-1.5	510-00107
2"	2.950	2.060	KF-50	SMV-304-LWF-KF50-2.0	561-00030	SMV-316L-LWF-KF50-2.0	561-00133

* 304L available upon request

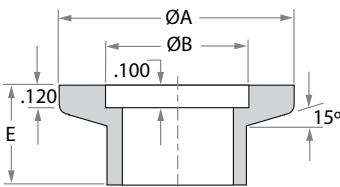

KF Short Butt Weld Flanges

O.D. Size inch	A inch	B inch	E inch	Type	304**		316L	
					Name	Catalog #	Name	Catalog #
½"	1.180	0.480	0.500	KF-10	SMV-304-SWF-KF10-0.5	561-00003	*	
¾"	1.180	0.680	0.500	KF-16	SMV-304-SWF-KF16-0.75	561-00009	*	
1"	1.575	1.031	0.500	KF-25	SMV-304-SWF-KF25-1.0	561-00018	SMV-316L-SWF-KF25-1.0	510-00177
1½"	2.160	1.620	0.750	KF-40	SMV-304-SWF-KF40-1.5	561-00061	SMV-316L-SWF-KF40-1.5	510-00106
2"	2.950	2.060	0.750	KF-50	SMV-304-SWF-KF50-2.0	561-00060	SMV-316L-SWF-KF50-2.0	510-00178

* Upon Request

** 304L available upon request

KF Wingnut Clamps Aluminum

O.D. Size inch	A inch	B inch	C inch	Type	Name	Catalog #
½" - ¾"	1.690	2.392	0.625	KF-16	SMV-ALU-WNC-KF10 / 16-0.5 / 0.75	570-00012
1"	2.140	2.796	0.625	KF-25	SMV-ALU-WNC-KF25-1.0	570-00011
1½"	2.750	3.437	0.625	KF-40	SMV-ALU-WNC-KF40-1.5	570-00005
2"	3.500	4.245	0.710	KF-50	SMV-ALU-WNC-KF50-2.0	570-00004

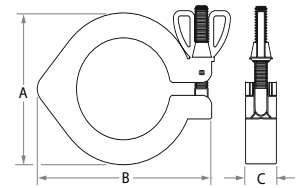

KF Wingnut Clamps S.Steel 304

O.D. Size inch	A inch	B inch	C inch	Type	Name	Catalog #
½" - ¾"	1.653	2.480	0.610	KF-16	SMV-SS-WNC-KF10 / 16-0.5 / 0.75	570-00032
1"	2.007	2.992	0.610	KF-25	SMV-SS-WNC-KF25-1.0	570-00027
1½"	2.559	3.700	0.629	KF-40	SMV-SS-WNC-KF40-1.5	570-00029
2"	3.346	4.783	0.708	KF-50	SMV-SS-WNC-KF50-2.0	570-00034

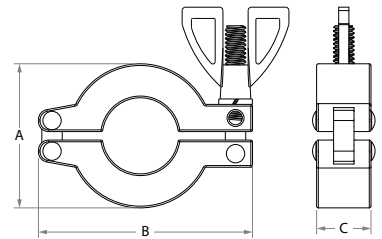

KF Toggle Clamps Aluminum

O.D. Size inch	A inch	B inch	C inch	D inch	E inch	Type	Name	Catalog #
½" - ¾"	2.717	3.819	0.787	2.480	1.693	KF-16	MV-ALU-TGCL-KF10/16-0.5/0.75	570-00015
1"	2.953	4.173	0.787	2.913	1.693	KF-25	SMV-ALU-TGCL-KF25-1.0	570-00016
1½"	3.346	4.843	0.787	3.543	1.693	KF-40	SMV-ALU-TGCL-KF40-1.5	570-00017
2"	4.646	6.496	0.906	4.528	1.693	KF-50	SMV-ALU-TGCL-KF50-2.0	570-00018

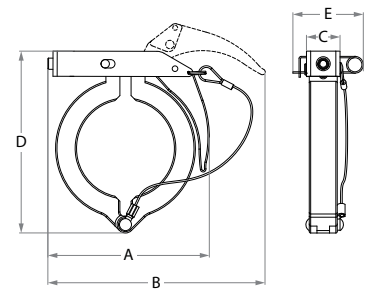

KF Toggle Clamps S.Steel 304

O.D. Size inch	A inch	B inch	C inch	D inch	E inch	Type	Name	Catalog #
½" - ¾"	2.717	3.819	0.787	2.480	1.693	KF-16	SMV-SS-TGCL-KF10 / 16-0.5 / 0.75	570-00036
1"	2.953	4.173	0.787	2.913	1.693	KF-25	SMV-SS-TGCL-KF25-1.0	570-00038
1½"	3.346	4.843	0.787	3.543	1.693	KF-40	SMV-SS-TGCL-KF40-1.5	570-00040
2"	4.646	6.496	0.906	4.528	1.693	KF-50	SMV-SS-TGCL-KF50-2.0	570-00042

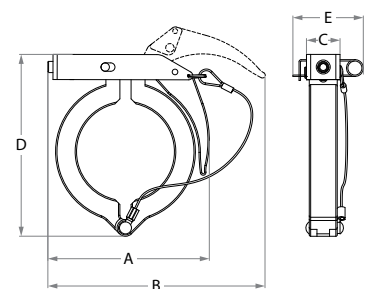

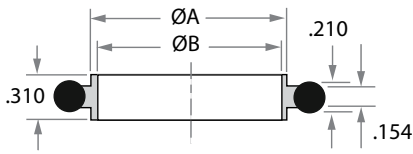

KF Centering Ring Assembly with Viton®* O-ring

O.D. Size inch	A inch	B inch	Type	304		316L	
				Name	Catalog #	Name	Catalog #
½"	0.478	0.438	KF-10	SMV-304-CRA-KF10-0.5	569-00016	SMV-316L-CRA-KF10-0.5	569-00060
¾"	0.669	0.625	KF-16	SMV-304-CRA-KF16-0.75	569-00015	SMV-316L-CRA-KF16-0.75	569-00061
1"	1.024	0.984	KF-25	SMV-304-CRA-KF25-1.0	569-00012	SMV-316L-CRA-KF25-1.0	569-00052
1½"	1.614	1.570	KF-40	SMV-304-CRA-KF40-1.5	569-00013	SMV-316L-CRA-KF40-1.5	569-00062
2"	2.047	1.967	KF-50	SMV-304-CRA-KF50-2.0	569-00014	SMV-316L-CRA-KF50-2.0	569-00063

* Kalrez and Chemraz - Upon Request

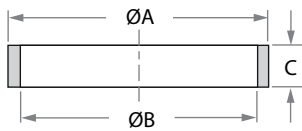

KF Overpressure Rings 304 Stainless steel

O.D. Size inch	A inch	B inch	C inch	Type	Max. PSIG	Name	Catalog # 304
½" - ¾"	1.250	1.186	0.346	KF-16	100	SMV-304-OPR-KF10/16-0.5/0.75	569-00006
1"	1.660	1.583	0.346	KF-25	100	SMV-304-OPR-KF25-1.0	569-00007
1½"	2.250	2.169	0.346	KF-40	75	SMV-304-OPR-KF40-1.5	569-00008
2"	2.750	2.620	0.145	KF-50	50	SMV-304-OPR-KF50-2.0	569-00004



KIT - KF Centering Ring Assembly with Viton®* O-ring Aluminium Over pressure ring

O.D. Size inch	A inch	Length	Type	304		316L	
				Name	Catalog #	Name	Catalog #
1"	1.670	0.980	KF-25	SMV-304-CRA-ALOPR-KF25-1.0	508-00004	SMV-316L-CRA-ALOPR-KF25-1.0	510-00096
1½"	2.240	1.570	KF-40	SMV-304-CRA-ALOPR-KF40-1.5	508-00005	SMV-316L-CRA-ALOPR-KF40-1.5	510-00036
2"	3.050	1.960	KF-50	SMV-304-CRA-ALOPR-KF50-2.0	508-00006	SMV-316L-CRA-ALOPR-KF50-2.0	510-00039

* Kalrez and Chemraz - Upon Request

Kit are made of different components than the KF Centering ring and over pressure ring (see tables above - they are supplied stand alone)

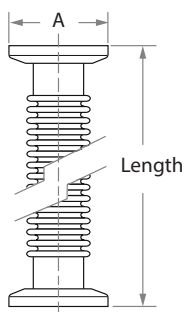

KF Flex Bellow

O.D. Size inch	A inch	Type	Length	Compressed length	304		316L	
					Name	Catalog #	Name	Catalog #
½"	1.180	KF-10	3.2	2.720	SMV-304-FB-KF10-0.5	514-00009	SMV-316L-FB-KF10-0.5	*
¾"	1.180	KF-16	3.2	2.720	SMV-304-FB-KF16-0.75	514-00018	SMV-316L-FB-KF16-0.75	*
1"	1.575	KF-25	4.2	3.678	SMV-304-FB-KF25-1.0	514-00001	SMV-316L-FB-KF25-1.0	510-00147
1½"	2.160	KF-40	4.2	3.678	SMV-304-FB-KF40-1.5	514-00002	SMV-316L-FB-KF40-1.5	510-00148
2"	2.950	KF-50	4.2	3.678	SMV-304-FB-KF50-2.0	514-00003	SMV-316L-FB-KF50-2.0	510-00149

* Upon Request

KF Weld Flanges & Fittings

Conical Reducers With Flanges

Flange 1	Flange 2	Name	Catalog # 304*
KF-25	KF-16	SMV-BW-304-CORD-1.0X0.75-FLG	507-00119
KF-40	KF-25	SMV-BW-304-CORD-1.5X1.0-FLG	507-00120
FK-50	KF-25	SMV-BW-304-CORD-2.0X1.0-FLG	507-00121
FK-50	KF-40	SMV-BW-304-CORD-2.0X1.5-FLG	507-00122

* 304L available upon request

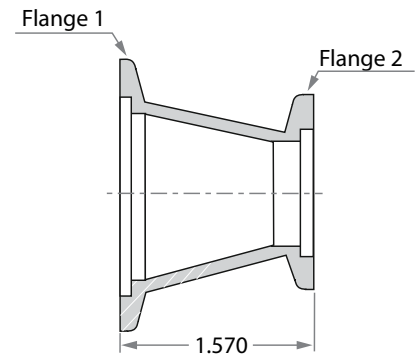

KF 90° Elbows With Flanges

O.D. Size inch	A inch	Type	Name	Catalog # 304*
1.000	1.65"	KF-25	SMV-BW-304-EL90-1.0-FLG	503-00059
1.500	2.4"	KF-40	SMV-BW-304-EL90-1.5-FLG	503-00116
2.000	3.15"	KF-50	SMV-BW-304-EL90-2.0-FLG	503-00114

* 304L available upon request

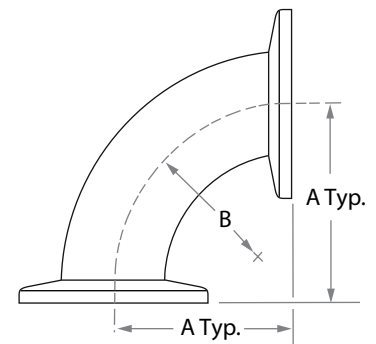

KF 45° Elbows With Flanges

O.D. Size inch	A inch	Type	Name	Catalog # 304*
1.000	1.12"	KF-25	SMV-BW-304-EL45-1.0-FLG	503-00118
1.500	1.68"	KF-40	SMV-BW-304-EL45-1.5-FLG	503-00119
2.000	1.99"	KF-50	SMV-BW-304-EL45-2.0-FLG	503-00113

* 304L available upon request

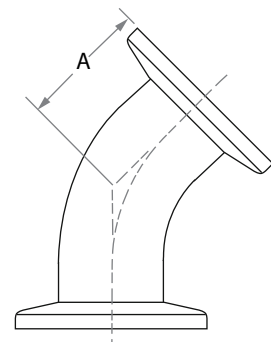

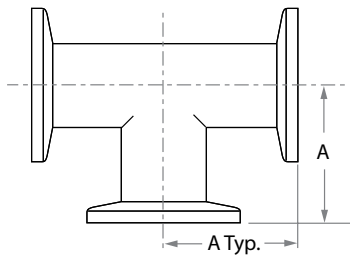

KF Equal TEE 45° With Flanges

O.D. Size inch	A inch	Name	Catalog # 304*
¾"	2.025	SMV-BW-304-TEE-0.75-FLG	505-00084
1.0"	2.025	SMV-BW-304-TEE-1.0-FLG	510-00110
1.5"	2.405	SMV-BW-304-TEE-1.5-FLG	505-00085
2.0"	3.150	SMV-BW-304-TEE-2.0-FLG	505-00086

* 304L available upon request

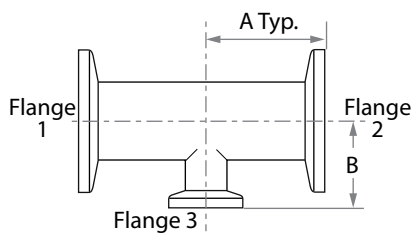

KF Reducer Tees With Flanges

Size Flange 1 & 2	Size Flange 3	A inch	B inch	Name	Catalog # 304*
1.0"	¾"	2.275	2.275	SMV-BW-304-RTEE-1.0X0.75-FLG	505-00094
1.5"	1.0"	2.525	2.525	SMV-BW-304-RTEE-1.5X1.0-FLG	505-00095
2.0"	1.0"	2.525	2.525	SMV-BW-304-RTEE-2.0X1.0-FLG	505-00096
2.0"	1.5"	2.525	2.650	SMV-BW-304-RTEE-2.0X1.5-FLG	505-00097

* 304L available upon request

ISO Flanges

General

ISO flanges conform with vacuum flange standards issued by the International Standards Organization (ISO). They share the same underlying concept as the KF flange series in that two faced sexless flanges clamp together with a sealing device between them. Each flange face has a counter - bore and a fitting metal ring with an elastomeric O - ring around its outer diameter.

The centering ring has two roles:

1. It aligns the flanges.
2. It prevents the O - ring from being pushed in by the external atmospheric pressure when the joint is under vacuum.

ISO flanges have two clamping mechanisms holding the flanges together:

1. The first uses separate clamps hooked over the outer edge of the mating flanges and spaced around the circumference (Figure A).
2. The second uses conventional bolt holes in the flange periphery.

Egmo's ISO flanges are hold together by using separate clamps (1 above) hooked over the outer edge of the mating flanges and spaced around the circumference (see Figure A in Page 16).

The clear advantage of the multi - part flange is that it mates simply by using the appropriate pieces in the assembly.

Specifications

The EGMO ISO flange system is designed and manufactured according to ISO standard 2861/1 for simple constructing of vacuum systems in the semiconductor industry.

The ISO flange connection system is shown in Figure A in Page 16.

ISO components can be used with standard clamps and aluminium seals to obtain a UHV seal up to 150°C. Double claw clamps are used when a pair of flanges is joined as seen in Figure A in Page 16.

The flange interface dimensions are machined according to international standards.

EGMO also offers 316L stainless steel ISO flange fittings for rugged corrosion resistance in semiconductor processing, with excellent repeatability in high vacuum applications.

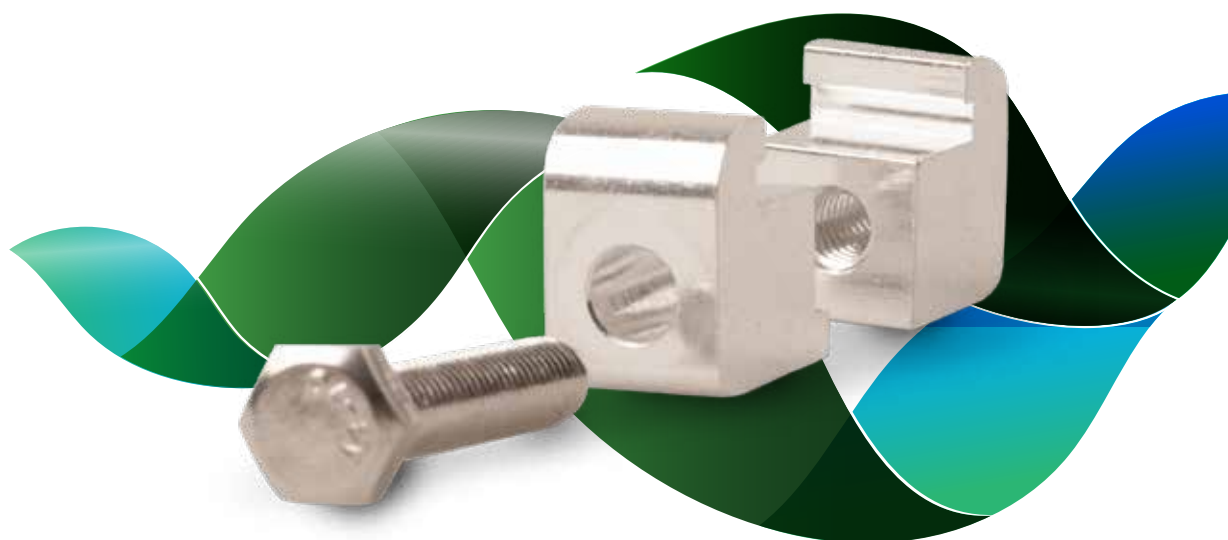

A. Double Claw Clamp connection

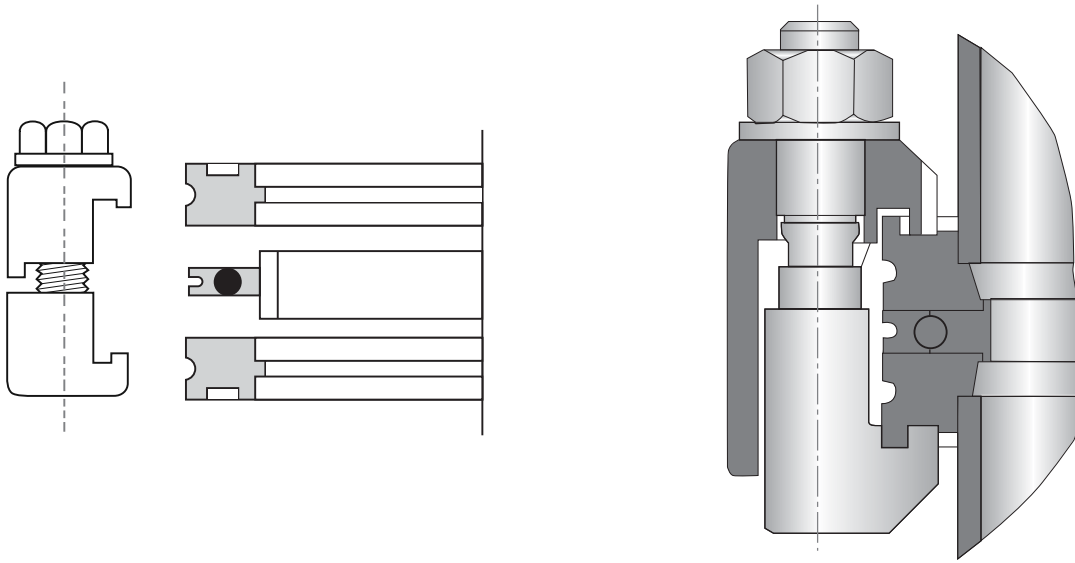

How to order

ISO Fittings:

S M V - **3 0 4 L** - **C R A** - **I S O 1 6 0** - **3 . 0**
 Product Line Material Description Type O.D. Size Inch

Product line	Material	Description	Type	O.D. Size Inch
SMV - SCiMax Vacuum	304	BOF - Board Flange	ISO63	2.5
		BLF - Blind Flange	ISO80	3.0
		LWF - Long Weld Flange	ISO100	4.0
	316L	HNF - Half Nipple Flange	ISO160	6.0
		CRA - Centering Ring Assembly	ISO200	8.0
	ALU - Aluminium*	DCC - Double Claw Clamp	ISO250	10.0
		FB - Flex Bellow	ISO 320	12.75

* Aluminum option can be used only for OPR

ISO Blind Flanges

O.D. Size inch	Flange Size	A inch	304***		316L	
			Name	Catalog #	Name	Catalog #
2½"	ISO-63	3.740	SMV-304-BLF-ISO63-2.5	511-00009	SMV-316L-BLF-ISO63-2.5	*
3"	ISO-80	4.331	SMV-304-BLF-ISO80-3.0	511-00006	SMV-316L-BLF-ISO80-3.0	510-00145
4"	ISO-100	5.118	SMV-304-BLF-ISO100-4.0	511-00010	SMV-316L-BLF-ISO100-4.0	510-00146
6"	ISO-160	7.087	SMV-304-BLF-ISO160-6.0	511-00005	SMV-316L-BLF-ISO160-6.0	510-00099
8"	ISO-200	9.449	SMV-304-BLF-ISO200-8.0	511-00022	SMV-316L-BLF-ISO200-8.0	510-00195
10"	ISO-250	11.420	SMV-304-BLF-ISO250-10.0	511-00023	SMV-316L-BLF-ISO250-10.0	510-00196
12.75"	ISO-320	14.56	SMV-304-BLF-ISO320-12.75	515-00057	SMV-316L-BLF-ISO320-12.75	*

* Upon Request

** 0.67 for O.D.12.75" Only

*** 304L available upon request

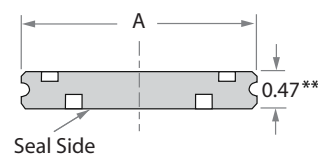

ISO Board Flanges

O.D. Size inch	Flange Size	A inch	B inch	C inch	D inch	304**		316L	
						Name	Catalog #	Name	Catalog #
2½"	ISO-63	3.740	0.470	2.438	2.510	SMV-304-BOF-ISO63-2.5	511-00054	SMV-316L-BOF-ISO63-2.5	510-00199
3"	ISO-80	4.331	0.470	2.938	3.010	SMV-304-BOF-ISO80-3.0	511-00002	SMV-316L-BOF-ISO80-3.0	510-00043
4"	ISO-100	5.118	0.470	3.910	4.010	SMV-304-BOF-ISO100-4.0	511-00003	SMV-316L-BOF-ISO100-4.0	510-00007
6"	ISO-160	7.087	0.470	5.875	6.020	SMV-304-BOF-ISO160-6.0	511-00008	SMV-316L-BOF-ISO160-6.0	510-00001
8"	ISO-200	9.449	0.470	7.875	8.020	SMV-304-BOF-ISO200-8.0	511-00011	SMV-316L-BOF-ISO200-8.0	510-00200
10"	ISO-250	11.417	0.470	9.875	10.020	SMV-304-BOF-ISO250-10.0	511-00021	SMV-316L-BOF-ISO250-10.0	510-00201
12.75"	ISO-320	14.566	0.669	12.811	10.020	SMV-304-BOF-ISO320-12.75	511-00058	SMV-316L-BOF-ISO320-12.75	*

* Upon Request

** 304L available upon request

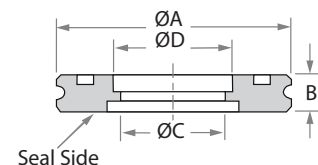

ISO Double Claw Clamps - Aluminum

Flange Size	A inch	B inch	Thread Size	Clamps Required	Name	Catalog # 304L
ISO63 - ISO100	0.940	1.960	5/16-18	4-6	SMV-ALU-DCC-ISO63-100-2.5-4.0	512-00007
ISO160 - ISO250	1.100	1.96	5/16 -18	6-10	SMV-ALU-DCC-ISO160-250-6.0-10.0	512-00003
ISO320	1.340	2.590	5/16 -18	12	SMV-ALU-DCC-ISO320-12.75	512-00019

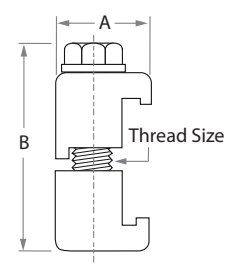

ISO Double Claw Clamps - Stainless Steel

Flange Size	A inch	B inch	Clamps Required	Name	Catalog # 304
ISO63 - ISO250	0.886	1.595	4-10	SMV-304-DCC-ISO63-250-ZNUT	512-00017

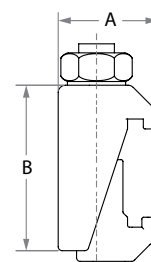

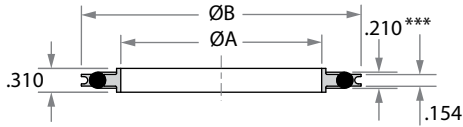

KIT - ISO Centering Rings with Viton® O-ring and Aluminum Spacer Ring

Type	A inch	B inch	304		316L	
			Name	Catalog #	Name	Catalog #
ISO-63	2.630	3.671	SMV-304-CRA-SR-ISO63-2.5	569-00029	SMV-316L-CRA-SR-ISO63-2.5	510-00136
ISO-80	3.140	4.031	SMV-304-CRA-SR-ISO80-3.0	515-00002	SMV-316L-CRA-SR-ISO80-3.0	510-00054
ISO-100	3.890	4.010	SMV-304-CRA-SR-ISO100-4.0	515-00003	SMV-316L-CRA-SR-ISO100-4.0	510-00060
ISO-160	5.900	7.010	SMV-304-CRA-SR-ISO160-6.0	515-00004	SMV-316L-CRA-SR-ISO160-6.0	510-00002
ISO-200	8.260	9.421	SMV-304-CRA-SR-ISO200-8.0	515-00013	SMV-316L-CRA-SR-ISO200-8.0	510-00137
ISO-250	10.120	11.349	SMV-304-CRA-SR-ISO250-10.0	515-00022	SMV-316L-CRA-SR-ISO250-10.0	510-00138
ISO-320	12.283	14.090	SMV-304-CRA-SR-ISO320-12.75	515-00057	SMV-316L-CRA-SR-ISO320-12.75	**

* Kalrez and Chemraz - Upon Request

** Upon Request

*** 0.271" for ISO-320 Only

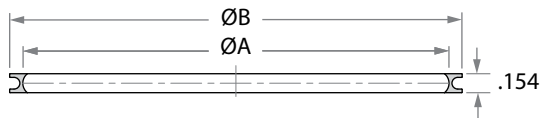

ISO Aluminum Spacer Ring

Type	A inch	B inch	Name	Catalog #
ISO-63	3.449	3.661	SMV-ALU-SR-ISO63-2.5	569-00089
ISO-80	3.957	4.291	SMV-ALU-SR-ISO80-3.0	569-00031
ISO-100	4.709	5.039	SMV-ALU-SR-ISO100-4.0	569-00033
ISO-160	6.717	7.000	SMV-ALU-SR-ISO160-6.0	569-00035
ISO-200	9.079	9.409	SMV-ALU-SR-ISO200-8.0	569-00037
ISO-250	10.748	11.339	SMV-ALU-SR-ISO250-10.0	569-00039
ISO-320	13.523	14.078	SMV-ALU-SR-ISO320-12.75	569-00088

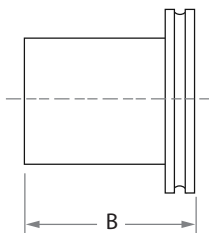

ISO Half Nipples

O.D. Size inch	Type	B inch	304*		316L	
			Name	Catalog #	Name	Catalog #
2½"	ISO-63	3.940	SMV-304-HNF-ISO63-2.5	561-00132	SMV-316L-HNF-ISO63-2.5	510-00204
3"	ISO-80	3.940	SMV-304-HNF-ISO80-3.0	561-00105	SMV-316L-HNF-ISO80-3.0	510-00141
4"	ISO-100	3.940	SMV-304-HNF-ISO100-4.0	561-00109	SMV-316L-HNF-ISO100-4.0	510-00142
6"	ISO-160	3.940	SMV-304-HNF-ISO160-6.0	561-00101	SMV-316L-HNF-ISO160-6.0	510-00170
8"	ISO-200	7.380	SMV-304-HNF-ISO200-8.0	561-00103	SMV-316L-HNF-ISO200-8.0	510-00205

* 304L available upon request

ISO Flexible Bellow

O.D. Size inch	Flange Type	Length	Compressed Length	304		316L	
				Name	Catalog #	Name	Catalog #
2½"	ISO-63	7.000	6.000	SMV-304-FB-ISO63-2.5	563-00025	SMV-316L-FB-ISO63-2.5	510-00189
3"	ISO-80	7.000	6.000	SMV-304-FB-ISO80-3.0	563-00001	SMV-316L-FB-ISO80-3.0	510-00150
4"	ISO-100	7.000	6.000	SMV-304-FB-ISO100-4.0	563-00002	SMV-316L-FB-ISO100-4.0	510-00103
6"	ISO-160	7.000	6.000	SMV-304-FB-ISO160-6.0	563-00017	SMV-316L-FB-ISO160-6.0	510-00190
8"	ISO-200	7.000	6.000	SMV-304-FB-ISO200-8.0	563-00018	SMV-316L-FB-ISO200-8.0	510-00191
10"	ISO-250	8.000	7.000	SMV-304-FB-ISO250-10.0	563-00019	SMV-316L-FB-ISO250-10.0	510-00192

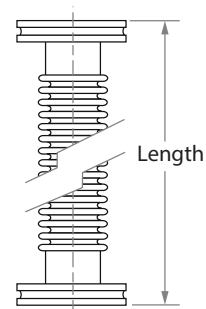

ISO Flexible Bellow - Short

O.D. Size inch	Flange Type	Length	Compressed Length	Name	Catalog #
2½"	ISO-63	6.000	5.000	SMV-304-FB-ISO63-2.5-L6.0	563-00027
3"	ISO-80	6.000	5.000	SMV-304-FB-ISO80-3.0-L6.0	563-00029
4"	ISO-100	6.000	5.000	SMV-304-FB-ISO100-4.0-L6.0	563-00031

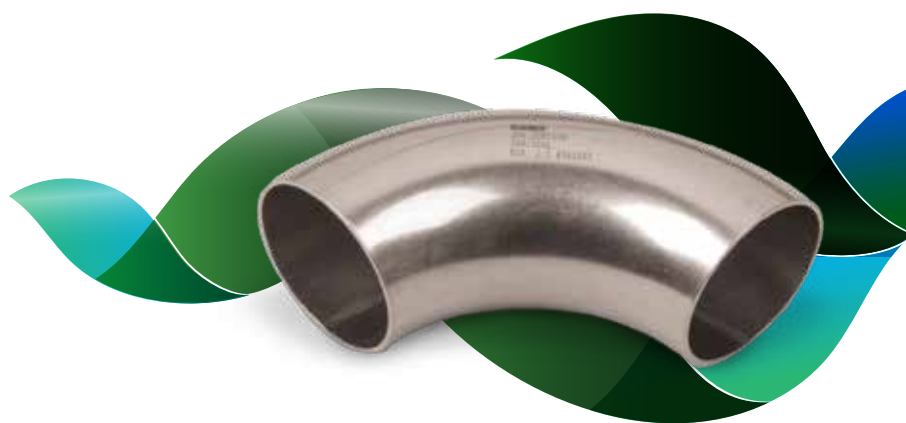

ISO Flanged Fittings

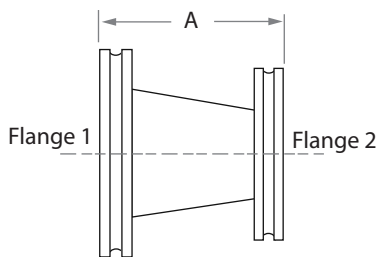

ISO Conical Reducer Nipples With Flanges

Flange 1	Flange 2	A inch	Name	Catalog # 304**
ISO-80	KF-40	4.000	SMV-BW-304-CORD-3.0X1.5-FLG	507-00123
ISO-80	KF-50	4.000	SMV-BW-304-CORD-3.0X2.0-FLG	507-00124
ISO-100	KF-40	4.000	SMV-BW-304-CORD-4.0X1.5-FLG	507-00125
ISO-100	KF-50	4.000	SMV-BW-304-CORD-4.0X2.0-FLG	507-00126
ISO-100	ISO-80	4.120	SMV-BW-304-CORD-4.0X3.0-FLG	507-00107

* ISO150 and ISO200 - Upon Request

** 304L available upon request

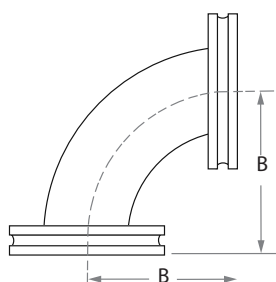

ISO 90° Radius Elbows With Flanges

OD Size [Inch]	B size	Name	Catalog # 304*
3.0"	4.750	SMV-BW-304-EL90-3.0-FLG	503-00117
4.0"	6.250	SMV-BW-304-EL90-4.0-FLG	510-00109

* 304L available upon request

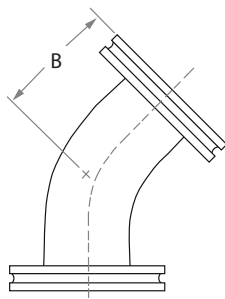

ISO 45° Radius Elbows With Flanges

OD Size [Inch]	B size	Name	Catalog # 304*
3.0"	3.930	SMV-BW-304-EL45-3.0-FLG	503-00120
4.0"	5.030	SMV-BW-304-EL45-4.0-FLG	503-00121

* 304L available upon request

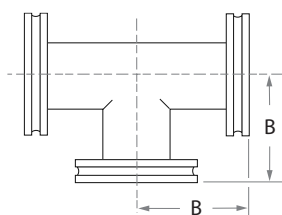

ISO Equal TEE With Flanges

OD Size [Inch]	B size	Name	Catalog # 304*
3.0"	3.500	SMV-BW-304-TEE-3.0-FLG	505-00087
4.0"	4.130	SMV-BW-304-TEE-4.0-FLG	505-00088

* 304L available upon request

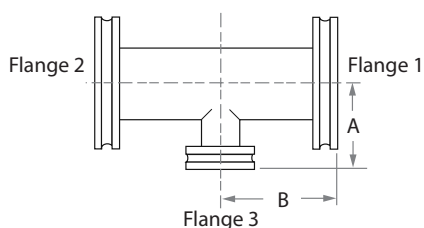

ISO Reducer Tees With Flanges

Size Flange 1 & 2	Size Flange 3	A size	B size	Name	Catalog # 304*
3.0	1.5	3.400	3.500	SMV-BW-304-RTEE-3.0X1.5-FLG TG	505-00098
3.0	2.0	3.150	3.500	SMV-BW-304-RTEE-3.0X2.0-FLG TG	505-00099
4.0	2.0	4.150	4.000	SMV-BW-304-RTEE-4.0x2.0-FLG TG	505-00100
4.0	3.0	3.900	4.000	SMV-BW-304-RTEE-4.0x3.0-FLG TG	505-00101

* 304L available upon request

ISO Weld Fittings

General

EGMO designs and manufactures a complete butt - weld vacuum fittings line together with its full line of NW, ISO and flanges.

The standard material supplied for fittings is type 304, 304L stainless steel, specifically prepared for use in high vacuum processes or UHV applications. Special 316L material can be supplied on request.

Butt - weld fittings are used in vacuum applications where minimizing the number of sealed joints is critical. EGMO butt-weld vacuum fittings are TIG welded, while perfectly aligning the welding segments to ensure complete penetration.

All Butt - Weld fittings are leak free and cleaned for high vacuum use and then marked with the heat number of raw material, size and job number enabling full traceability to all material used, and to EGMO production data. Full Material Test Reports (MTR) are supplied with the finished goods, or via the EGMO website, indicating the item job number. EGMO butt - weld vacuum fittings are packed in individual bags. All EGMO butt - weld vacuum fittings are individually labelled for easy identification.

EGMO develops and fabricates Stainless tubular fittings for the semiconductor industry.

The fittings are suitable for welding (orbital or manual) and available in 1/2" - 12.75" OD sizes. AISI 316L materials is available upon request. The fittings are fabricated according to ASTM A - 270 / ASTM A - 269 requirements. Surface finish is on sizes 1"-6" polished Bright Annealed. Other surface finishes are available upon request.

How to order

But Weld Fittings:

S **M** **V** - **B** **W** - **3** **0** **4** **L** - **E** **L** **9** **0** - **1** **.** **0** - **T** **G**

Product Line

Type

Material

Description

O.D. Size

Tangent

Product line	Type	Material	Description	O.D. Size	Tangent
SMV - SciMax Vacuum	BW - Butt Weld Fittings	304	EL90 - Elbows 90	0.5	TG - with Tangent
		304L	EL45 - Elbows 45	0.75	Blank - No Tangent
		316L	TEE - Tee	1.0	
			RTEE - Reduce TEE	1.5	
			CORD - Conical Reducer	2.0	
			ECAP - End Cap	2.5	
				3.0	
				4.0	
				6.0	
				8.0	
				10.0	
	12.75				

90° Radius Elbows - Type 1

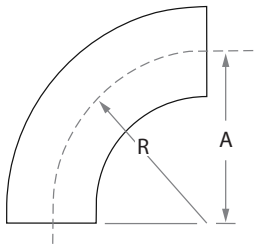

O.D. Size inch	A inch	R	304****		316L	
			Name	Catalog #	Name	Catalog #
½"	0.750	0.750	SMV-BW-304-EL90-0.5	503-00101	SMV-BW-316L-EL90-0.5	503-00190
¾"	1.126	1.126	SMV-BW-304-EL90-0.75	503-00035	SMV-BW-316L-EL90-0.75	503-00191
1"	1.500	1.500	SMV-BW-304-EL90-1.0	503-00005	SMV-BW-316L-EL90-1.0	503-00152
1½"	2.250	2.250	SMV-BW-304-EL90-1.5	503-00013	SMV-BW-316L-EL90-1.5	503-00154
2"	3.000	3.000	SMV-BW-304-EL90-2.0	503-00020	SMV-BW-316L-EL90-2.0	503-00156
2½"	3.750	3.750	SMV-BW-304-EL90-2.5	503-00027	SMV-BW-316L-EL90-2.5	503-00192
3"	4.500	4.500	SMV-BW-304-EL90-3.0	503-00032	SMV-BW-316L-EL90-3.0	503-00158
4"	6.000	6.000	SMV-BW-304-EL90-4.0	503-00040	SMV-BW-316L-EL90-4.0	503-00160
6"	9.000	9.000	SMV-BW-304-EL90-6.0	503-00044	SMV-BW-316L-EL90-6.0	503-00174
8"	12.000	12.000	SMV-BW-304-EL90-8.0	503-00049	SMV-BW-316L-EL90-8.0	503-00193
10"*	15.000	15.000	SMV-BW-304-EL90-10.0	503-00053	SMV-BW-316L-EL90-10.0	503-00194
12.75" **	19.125	19.125	SMV-BW-304-EL90-12.75	503-00223	SMV-BW-316L-EL90-12.75	***

* ASTM A-774

** ASTM A-403

*** Upon Request

**** 304L available upon request

90° Radius Elbows with Tangents - Type 2

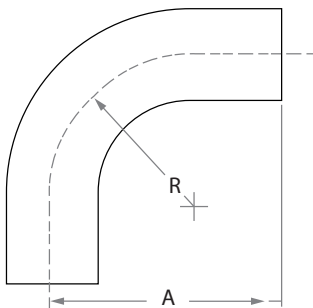

O.D. Size inch	A inch	R	304*		316L	
			Name	Catalog #	Name	Catalog #
½"	1.126	0.750	SMV-BW-304-EL90-0.5-TG	503-00105	SMV-BW-316L-EL90-0.5-TG	503-00195
¾"	1.420	1.126	SMV-BW-304-EL90-0.75-TG	503-00102	SMV-BW-316L-EL90-0.75-TG	503-00196
1"	1.820	1.500	SMV-BW-304-EL90-1.0-TG	503-00006	SMV-BW-316L-EL90-1.0-TG	503-00128
1½"	2.940	2.250	SMV-BW-304-EL90-1.5-TG	503-00015	SMV-BW-316L-EL90-1.5-TG	503-00129
2"	4.060	3.000	SMV-BW-304-EL90-2.0-TG	503-00022	SMV-BW-316L-EL90-2.0-TG	503-00130
2½"	5.190	3.750	SMV-BW-304-EL90-2.5-TG	503-00029	SMV-BW-316L-EL90-2.5-TG	503-00197
3"	6.310	4.500	SMV-BW-304-EL90-3.0-TG	503-00034	SMV-BW-316L-EL90-3.0-TG	503-00131
4"	8.310	6.000	SMV-BW-304-EL90-4.0-TG	503-00042	SMV-BW-316L-EL90-4.0-TG	503-00132

* 304L available upon request

45° Radius Elbows - Type 1

O.D. Size inch	A inch	R	304****		316L	
			Name	Catalog #	Name	Catalog #
½"	0.310	0.750	SMV-BW-304-EL45-0.5	503-00055	SMV-BW-316L-EL45-0.5	503-00180
¾"	0.470	1.126	SMV-BW-304-EL45-0.75	503-00056	SMV-BW-316L-EL45-0.75	503-00181
1"	0.620	1.500	SMV-BW-304-EL45-1.0	503-00003	SMV-BW-316L-EL45-1.0	503-00162
1½"	0.930	2.250	SMV-BW-304-EL45-1.5	503-00010	SMV-BW-316L-EL45-1.5	503-00164
2"	1.250	3.000	SMV-BW-304-EL45-2.0	503-00018	SMV-BW-316L-EL45-2.0	503-00166
2½"	1.530	3.750	SMV-BW-304-EL45-2.5	503-00025	SMV-BW-316L-EL45-2.5	503-00182
3"	1.840	4.500	SMV-BW-304-EL45-3.0	503-00031	SMV-BW-316L-EL45-3.0	503-00168
4"	2.500	6.000	SMV-BW-304-EL45-4.0	503-00038	SMV-BW-316L-EL45-4.0	503-00170
6"	3.730	9.000	SMV-BW-304-EL45-6.0	503-00043	SMV-BW-316L-EL45-6.0	503-00109
8"	4.970	12.000	SMV-BW-304-EL45-8.0	503-00048	SMV-BW-316L-EL45-8.0	503-00183
10"*	6.220	14.170	SMV-BW-304-EL45-10.0	503-00054	SMV-BW-316L-EL45-10.0	503-00184
12.75" **	7.921	19.125	SMV-BW-304-EL45-12.75	503-00224	SMV-BW-316L-EL90-12.75	***

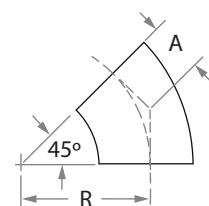

* ASTM A-774

** ASTM A-403

*** Upon Request

**** 304L available upon request

45° Radius Elbows with Tangents - Type 2

O.D. Size inch	A inch	R	304*		316L	
			Name	Catalog #	Name	Catalog #
¾"	0.760	1.126	SMV-BW-304-EL45-0.75-TG	503-00104	SMV-BW-316L-EL45-0.75-TG	503-00186
1"	1.190	1.500	SMV-BW-304-EL45-1.0-TG	503-00001	SMV-BW-316L-EL45-1.0-TG	503-00133
1½"	1.630	2.250	SMV-BW-304-EL45-1.5-TG	503-00011	SMV-BW-316L-EL45-1.5-TG	503-00134
2"	2.310	3.000	SMV-BW-304-EL45-2.0-TG	503-00017	SMV-BW-316L-EL45-2.0-TG	503-00135
2½"	3.000	3.750	SMV-BW-304-EL45-2.5-TG	503-00024	SMV-BW-316L-EL45-2.5-TG	503-00187
3"	3.680	4.500	SMV-BW-304-EL45-3.0-TG	503-00030	SMV-BW-316L-EL45-3.0-TG	503-00136
4"	4.810	6.000	SMV-BW-304-EL45-4.0-TG	503-00036	SMV-BW-316L-EL45-4.0-TG	503-00111

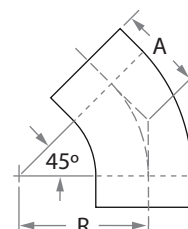

* 304L available upon request

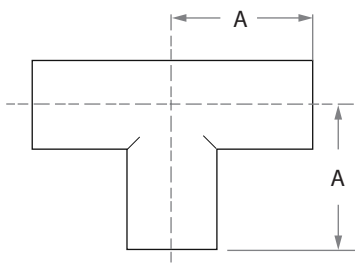

Equal TEE

O.D. Size inch	A inch	304****		316L	
		Name	Catalog #	Name	Catalog #
½"	0.750	SMV-BW-304-TEE-0.5	505-00015	SMV-BW-316L-TEE-0.5	505-00136
¾"	1.000	SMV-BW-304-TEE-0.75	505-00014	SMV-BW-316L-TEE-0.75	505-00137
1"	1.880	SMV-BW-304-TEE-1.0	505-00002	SMV-BW-316L-TEE-1.0	505-00110
1½"	2.250	SMV-BW-304-TEE-1.5	505-00005	SMV-BW-316L-TEE-1.5	505-00111
2"	3.000	SMV-BW-304-TEE-2.0	505-00008	SMV-BW-316L-TEE-2.0	505-00112
2½"	3.000	SMV-BW-304-TEE-2.5	505-00050	SMV-BW-316L-TEE-2.5	505-00138
3"	3.250	SMV-BW-304-TEE-3.0	505-00009	SMV-BW-316L-TEE-3.0	505-00113
4"	3.880	SMV-BW-304-TEE-4.0	505-00011	SMV-BW-316L-TEE-4.0	505-00114
6"	5.000	SMV-BW-304-TEE-6.0	505-00023	SMV-BW-316L-TEE-6.0	505-00139
8"	7.000	SMV-BW-304-TEE-8.0	505-00017	SMV-BW-316L-TEE-8.0	505-00140
10"*	8.500	SMV-BW-304-TEE-10.0	505-00021	SMV-BW-316L-TEE-10.0	505-00141
12.75" **	10.000	SMV-BW-304-TEE-12.75	505-00148	SMV-BW-316L-TEE-12.75	***

* ASTM A-774

** ASTM A-403

*** Upon Request

**** 304L available upon request

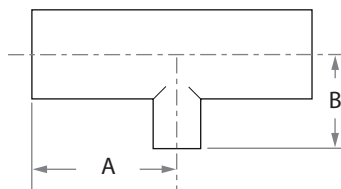

Reducer Tees

O.D. Size inch **	A inch	B inch	304***		316L	
			Name	Catalog #	Name	Catalog #
1" x ¾"	1.880	2.130	SMV-BW-304-RTEE-1.0X0.75	505-00001	SMV-BW-316L-RTEE-1.0X0.75	*
1½" x ¾"	2.250	2.250	SMV-BW-304-RTEE-1.5X0.75	505-00004	SMV-BW-316L-RTEE-1.5X0.75	*
1½" x 1"	2.250	2.380	SMV-BW-304-RTEE-1.5X1.0	505-00003	SMV-BW-316L-RTEE-1.5X1.0	505-00115
2" x 1"	3.000	2.380	SMV-BW-304-RTEE-2.0X1.0	505-00006	SMV-BW-316L-RTEE-2.0X1.0	505-00116
2" x 1½"	3.000	2.380	SMV-BW-304-RTEE-2.0X1.5	505-00007	SMV-BW-316L-RTEE-2.0X1.5	505-00117
2½" x 1½"	3.000	2.500	SMV-BW-304-RTEE-2.5X1.5	505-00061	SMV-BW-316L-RTEE-2.5X1.5	*
2½" x 2"	3.000	2.750	SMV-BW-304-RTEE-2.5X2.0	505-00051	SMV-BW-316L-RTEE-2.5X2.0	*
3" X 1½"	3.250	3.000	SMV-BW-304-RTEE-3.0X1.5	505-00063	SMV-BW-316L-RTEE-3.0X1.5	505-00118
3" x 2"	3.250	3.250	SMV-BW-304-RTEE-3.0X2.0	505-00028	SMV-BW-316L-RTEE-3.0X2.0	505-00119
3" x 2½"	3.250	3.250	SMV-BW-304-RTEE-3.0X2.5	505-00046	SMV-BW-316L-RTEE-3.0X2.5	*
4"x1.5"	3.880	3.500	SMV-BW-304-RTEE-4.0x1.5	505-00026	SMV-BW-316L-RTEE-4.0x1.5	*
4"x2"	3.880	4.000	SMV-BW-304-RTEE-4.0x2.0	505-00010	SMV-BW-316L-RTEE-4.0x2.0	505-00120
4" x 2½"	3.880	3.750	SMV-BW-304-RTEE-4.0x2.5	505-00052	SMV-BW-316L-RTEE-4.0x2.5	*
4" x 3"	3.880	3.750	SMV-BW-304-RTEE-4.0x3.0	505-00053	SMV-BW-316L-RTEE-4.0x3.0	505-00121
6" X 3"	5.000	4.750	SMV-BW-304-RTEE-6.0X3.0	505-00135	SMV-BW-316L-RTEE-6.0X3.0	*
6"x4	5.000	4.880	SMV-BW-304-RTEE-6.0X4.0	505-00027	SMV-BW-316L-RTEE-6.0X4.0	*
8"x6"	7.000	6.000	SMV-BW-304-RTEE-8.0X6.0	505-00029	SMV-BW-316L-RTEE-8.0X6.0	*
10"x8"	8.500	7.000	SMV-BW-304-RTEE-10.0X8.0	505-00030	SMV-BW-316L-RTEE-10.0X8.0	*

* Upon Request

** Other Sizes Upon Request

*** 304L available upon request

Conical Reducers - Type 1

O.D. Size inch	A inch	Name	Catalog # 304*
1" x 1/2"	1.500	SMV-BW-304-CORD-1.0X0.5	507-00018
1" x 3/4"	1.000	SMV-BW-304-CORD-1.0X0.75	507-00010
1 1/2" x 3/4"	3.000	SMV-BW-304-CORD-1.5X0.75	507-00012
1 1/2" x 1"	2.000	SMV-BW-304-CORD-1.5X1.0	507-00001
2" x 1"	4.000	SMV-BW-304-CORD-2.0X1.0	507-00002
2" x 1 1/2"	2.000	SMV-BW-304-CORD-2.0X1.5	507-00003
2 1/2" x 1 1/2"	4.000	SMV-BW-304-CORD-2.5X1.5	507-00014
2 1/2" x 2"	2.000	SMV-BW-304-CORD-2.5X2.0	507-00079
3" x 1.5"	6.000	SMV-BW-304-CORD-3.0X1.5	507-00105
3" x 2"	4.000	SMV-BW-304-CORD-3.0X2.0	507-00005
3" x 2 1/2"	2.000	SMV-BW-304-CORD-3.0X2.5	507-00007
4"x1.5"	10.000	SMV-BW-304-CORD-4.0X1.5	507-00035
4"x2"	8.000	SMV-BW-304-CORD-4.0X2.0	507-00006
4" x 2 1/2"	6.000	SMV-BW-304-CORD-4.0X2.5	507-00008
4" x 3"	4.000	SMV-BW-304-CORD-4.0X3.0	507-00009
6"x4"	4.000	SMV-BW-304-CORD-6.0X4.0	507-00015
8" x 6"	10.000	SMV-BW-304-CORD-8.0X6.0	507-00017
10" x 8"	7.000	SMV-BW-304-CORD-10.0X8.0	507-00025

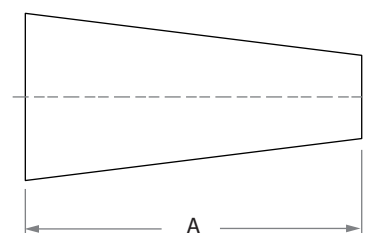

Other Sizes Upon Request

* 304L available upon request

Conical Reducers With Tangent - Type 2

O.D. Size inch	A inch	304**		316L	
		Name	Catalog #	Name	Catalog #
3/4" x 1/2"	*	SMV-BW-304-CORD-0.75X0.5TG	507-00069	*	
1" x 3/4"	1.380	SMV-BW-304-CORD-1.0X0.75 TG	507-00054	SMV-BW-316L-CORD-1.0X0.75 TG	*
1 1/2" x 1/2"	1.380	SMV-BW-304-CORD-1.5X0.5 TG	507-00071	SMV-BW-316L-CORD-1.5X0.5 TG	*
1 1/2" x 3/4"	2.380	SMV-BW-304-CORD-1.5X0.75 TG	507-00072	SMV-BW-316L-CORD-1.5X0.75 TG	*
1 1/2" x 1"	2.380	SMV-BW-304-CORD-1.5X1.0 TG	507-00073	SMV-BW-316L-CORD-1.5X1.0 TG	507-00135
2" x 1"	2.380	SMV-BW-304-CORD-2.0X1.0 TG	507-00076	SMV-BW-316L-CORD-2.0X1.0 TG	507-00136
2" x 1 1/2"	2.380	SMV-BW-304-CORD-2.0X1.5 TG	507-00077	SMV-BW-316L-CORD-2.0X1.5 TG	507-00137
2 1/2" x 2"	2.380	SMV-BW-304-CORD-2.5X2.0 TG	507-00083	SMV-BW-316L-CORD-2.5X2.0 TG	*
3" x 1 1/2"	3.630	SMV-BW-304-CORD-3.0X1.5 TG	507-00042	SMV-BW-316L-CORD-3.0X1.5 TG	507-00138
3" x 2"	3.630	SMV-BW-304-CORD-3.0X2.0 TG	507-00040	SMV-BW-316L-CORD-3.0X2.0 TG	507-00139
3" x 2 1/2"	3.630	SMV-BW-304-CORD-3.0X2.5 TG	507-00085	SMV-BW-316L-CORD-3.0X2.5 TG	*
4" x 1 1/2"	3.630	SMV-BW-304-CORD-4.0X1.5 TG	507-00044	SMV-BW-316L-CORD-4.0X1.5 TG	507-00140
4" x 2"	3.630	SMV-BW-304-CORD-4.0X2.0 TG	507-00059	SMV-BW-316L-CORD-4.0X2.0 TG	507-00141
4" x 2 1/2"	3.630	SMV-BW-304-CORD-4.0X2.5 TG	507-00087	SMV-BW-316L-CORD-4.0X2.5 TG	*
4" x 3"	3.630	SMV-BW-304-CORD-4.0X3.0 TG	507-00088	SMV-BW-316L-CORD-4.0X3.0 TG	507-00142
6" x 3"	5.500	SMV-BW-304-CORD-6.0X3.0 TG	507-00152	SMV-BW-316L-CORD-6.0X3.0 TG	*
6" x 4"	5.500	SMV-BW-304-CORD-6.0X4.0 TG	507-00046	SMV-BW-316L-CORD-6.0X4.0 TG	*

* Upon request

** 304L available upon request

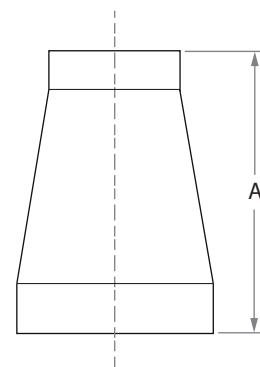

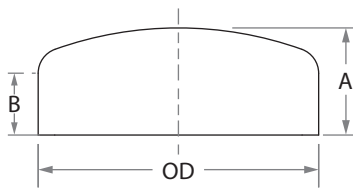

E-Cap

O.D. Size inch	A inch	B inch	304L		316L	
			Name	Catalog #	Name	Catalog #
0.50"	0.25"	0.14"	SMV-BW-304L-ECAP-0.5	506-00001	SMV-BW-316L-ECAP-0.5	506-00010
0.75"	0.31"	0.18"	SMV-BW-304L-ECAP-0.75	506-00002	SMV-BW-316L-ECAP-0.75	506-00011
1.00"	0.38"	0.22"	SMV-BW-304L-ECAP-1.0	506-00003	SMV-BW-316L-ECAP-1.0	506-00012
1.50"	0.50"	0.36"	SMV-BW-304L-ECAP-1.5	506-00004	SMV-BW-316L-ECAP-1.5	506-00013
2.00"	0.75"	0.51"	SMV-BW-304L-ECAP-2.0	506-00005	SMV-BW-316L-ECAP-2.0	506-00014
2.50"	1.00"	0.67"	SMV-BW-304L-ECAP-2.5	506-00006	SMV-BW-316L-ECAP-2.5	506-00015
3.00"	1.25"	0.90"	SMV-BW-304L-ECAP-3.0	506-00007	SMV-BW-316L-ECAP-3.0	506-00016
4.00"	1.50"	1.00"	SMV-BW-304L-ECAP-4.0	506-00008	SMV-BW-316L-ECAP-4.0	506-00017
6.00"	2.50"	1.70"	SMV-BW-304L-ECAP-6.0	506-00009	SMV-BW-316L-ECAP-6.0	506-00018

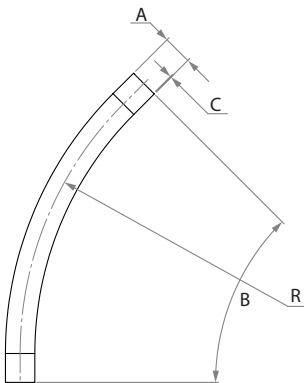

Long Radius Elbows 304L/316L

A	B
O.D. sizes	Angles
1" with R9 or R12	15°
1½" with R12	30°
2" with R18 or R24	45°
3" with R28	60°
	90°

* Sizes, wall thicknesses, radii and angles are upon request

Vacuum - Electro-polished Tubes & Fittings

SciMax Vacuum Electro Polished SM10

Product	SM10 316L Electropolished Tube and Fitting								
Specifications	ASTM A269, A270, A632								
Material Grade	316L								
Dimensional & Specification	Tubing	OD Size:	Wall Thickness:			Surface Finish:			
		½"	0.049"			Electropolished Ra=10 µ Inch			
		¾" through 3"	0.065"			Electropolished Ra=10 µ Inch			
		4"	0.083"			Electropolished Ra=10 µ Inch			
	6"	0.109"			Electropolished Ra=10 µ Inch				
		KF	Long Flange, Wing Nut Clamp						
	ISO	Half Nipple, Double Claw Clamp							
	Butt-weld	Elbow 45/ 90, Equal TEE, Reduced TEE, Reducer, End Cap							
	Kits:	KF	S.Steel Centring ring + Kalrez O-ring + Over pressure ring						
		ISO	S.Steel Centring ring + Kalrez O-ring + Spacer						
Chemical Composition 316L	%	C	Cr	Mn	Mo	Ni	P	Si	S
	min		16		2.0	10.0			
	max	0.030	18.0	2.0	3.0	14.0	0.045	1.00	0.030
Tube Length	Nominal Lengths				FT.		MT.		
					19-20		5.8-6.1		
Mechanical Tests	Hardness Test - 90 [Rockwell B] Max		ASTM A270 S2 (§ S2.3)						
Testing & Inspection:	Visual inspection								
	Dimensional measurement								
	Helium-leak testing when required								
Plain Ends	All tubing shall be Square ends ready for welding, with no chips, burs or other imperfections of the welding edge, that can influence the welding results.								
Cleaning	All tubing and Fittings surfaces shall be clean and free of oils, grease, particulates, grinding compounds, dust, rising residuals or electrolytes, and stains.								
Marking and Labeling	Tubes and Fittings shall be permanently marked or marked on the exterior of the bags with the following information.								
	Brand Name	Size O.D	Wall Thick.	Material Grade	Lot Number	Heat Number			
Packing	All products will be capped and packed with polyethylene sleeves.								
Certification	Inspection documents certification to be according to DIN EN10204 3.1. Full Material Tests Report (MTR) to be provided with the material. standard.								

How to order

Tubing:

S M 1 0 3 1 6 L E P S L - . 7 5 X 0 . 6 5
 Product Line Material Surface Treatment Type O.D. Size Wall Thickness Inch

Product Line	Material	Surface Treatment	Type	O.D. Size	Wall Thickness Inch
SM10 - SCiMax 10	316L	EP - Electro Polish	WE - Welded	½" - 0.5*	0.049
			SL - Seamless	¾" - 0.75*	0.065
				1" - 1.0**	0.065
				1 ½" - 1.5	0.065
				2" - 2.0	0.065
				2 ½" - 2.5	0.065
				3" - 3.0	0.065
				4" - 4.0	0.083
6" - 6.0	0.109				

* Seamless Only

** 1" can be ordered Seamless or Welded.

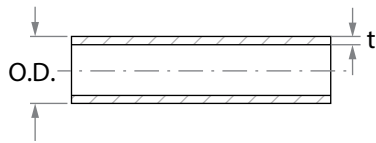

Tube Dimensions - EP

O.D. Size Inch	Type	Wall Thickness		Name	Catalog #
		t inch	t mm		
½"	Seamless	0.049	1.24	SM10316LEPSL-.5X.049SMT1	581-00238
¾"	Seamless	0.065	1.65	SM10316LEPSL-.75X.065SMT1	581-00239
1"	Seamless	0.065	1.65	SM10316LEPSL-1.0X.065SMT1	581-00240
1"	Welded	0.065	1.65	SM10316LEPWE-1.0X.065	581-00019
1 ½"	Welded	0.065	1.65	SM10306LEPWE-1.5X.065	581-00026
2"	Welded	0.065	1.65	SM10316LEPWE-2.0X.065	581-00028
2 ½"	Welded	0.065	1.65	SM10306LEPWE-2.5X.065	581-00029
3"	Welded	0.065	1.65	SM10316LEPWE-3.0X.065	581-00030
4"	Welded	0.083	2.11	SM10306LEPWE-4.0X.083	581-00031
6"	Welded	0.109	2.77	SM10306LEPWE-6.0X.109	581-00032

How to order - KF Fittings

S M V - 3 1 6 L - L W F - K F 2 5 - 1 . 0 - E P
 Product Line Material Description O.D. Size KF O.D. Size Inch Surface Finishing

Product Line	Material	Description	O.D. Size KF	O.D. Size Inch	Surface Finishing
SMV - SciMax Vacuum	316L	LWF - Long Weld Flange	KF25	1	EP - Electro Polish
		CRA - Centering Ring Assembly*	KF40	1.5	
			KF50	2	

* Kalrez

How to order - ISO Fittings

S M V - 3 1 6 L - H N F - I S O 1 0 0 - 4 . 0 - E P
 Product Line Material Description O.D. Size ISO O.D. Size Inch Surface Finishing

Product Line	Material	Description	O.D. Size ISO	O.D. Size Inch	Surface Finishing
SMV - SciMax Vacuum	316L	HNF - Half Nipple Flange	ISO 80	3	EP - Electro Polish
		CRA - Centering Ring Assembly*	ISO100	4	
			ISO160	6	

* Kalrez

How to order - Weld Fittings

S M 1 0 3 1 6 L E P E L 9 0 - 1 . 5
 Product Line Material Surface Finishing Description O.D. Size

Product Line	Material	Surface Finishing	Description	O.D. Size
SM10 - SciMax 10	316L	EP - Electro Polish	EL90 - Elbow 90	1" - 1.0
			EL45 - Elbow 45	1 ½" - 1.5
			ETEE - Equal Tee	2" - 2.0
			ECAP - End Cap	2 ½" - 2.5
				3" - 3.0
				4" - 4.0
	6" - 6.0			

How to order - Reducing Weld Fittings

S M 1 0 3 1 6 L E P R T E E - 3 . 0 X 2 . 0
 Product Line Material Surface Finishing Description O.D. Size Large O.D. Size Small

Product Line	Material	Surface Finishing	Description	O.D. Size Large	O.D. Size Small
SM10 - SciMax 10	316L	EP - Electro Polish BA - Bright Annealed	RTEE - Reducing Tee	1" - 1.0	¾" - 0.75
			CORD - Concentric Reducer	1 ½" - 1.5	1" - 1.0
				2" - 2.0	1 ½" - 1.5
				2 ½" - 2.5	2" - 2.0
				3" - 3.0	2 ½" - 2.5
				4" - 4.0	3" - 3.0
	6" - 6.0	4" - 4.0			

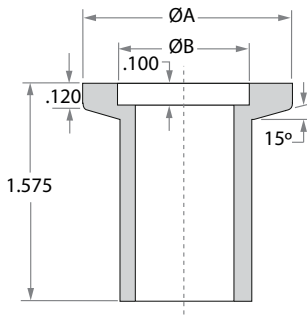

KF Long Butt Weld Flanges - EP (Electropolish)

O.D. Size inch	Type	A inch	B inch	C inch	Name	Catalog # 316L
1"	KF-25	1.575	1.031	0.870	SMV-316L-LWF-KF25-1.0EP	510-00163
1½"	KF-40	2.160	1.620	1.370	SMV-316L-LWF-KF40-1.5EP	510-00164
2"	KF-50	2.950	2.060	1.870	SMV-316L-LWF-KF50-2.0EP	510-00165

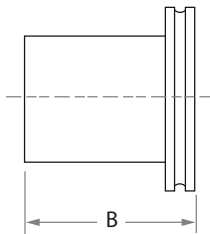

ISO Half Nipples - EP (Electropolish)

O.D. Size inch	Type	B inch	Name	Catalog # 316L
3"	ISO-80	3.940	SMV-316L-HNF-ISO80-3.0EP	510-00166
4"	ISO-100	3.940	SMV-316L-HNF-ISO100-4.0EP	510-00167
6"	ISO-160	3.940	SMV-316L-HNF-ISO160-6.0EP	510-00168

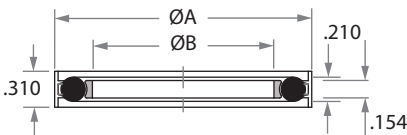

KIT - KF (Electropolish) Centering Ring with Kalrez® O-ring and Overpressure ring

Type	A inch	B inch	Name	Catalog # 316L
KF-16	1.270	0.620	SMV-316L-CRA-KLRZ-OPR-KF16-EP	508-00020
KF-25	1.670	0.980	SMV-316L-CRA-KLRZ-OPR-KF25-EP	508-00021
KF-40	2.260	1.570	SMV-316L-CRA-KLRZ-OPR-KF40-EP	508-00022
KF-50	3.050	1.960	SMV-316L-CRA-KLRZ-OPR-KF50-EP	508-00023

O-Ring - Kalrez® 8900

Other O-rings upon request

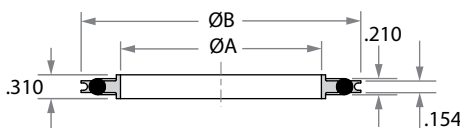

KIT - ISO (Electropolish) Centering Ring with Kalrez® O-ring and Spacer ring

Type	A inch	B inch	Name	Catalog # 316L
ISO-63	2.630	2.740	SMV-316L-CRA-KLRZ-SR-ISO63-EP	508-00035
ISO-80	3.140	3.250	SMV-316L-CRA-KLRZ-SR-ISO80-EP	508-00029
ISO-100	3.890	4.000	SMV-316L-CRA-KLRZ-SR-ISO100-EP	508-00030
ISO-160	5.900	6.010	SMV-316L-CRA-KLRZ-SR-ISO160-EP	508-00031

O-Ring - Kalrez® 8900

Other O-rings upon request

ECAP - End Cap - EP (Electropolish)

O.D. Size Inch	Dimensions				Name	Catalog # 316L
	A inch	A mm	B inch	B mm		
					SciMax 10	SciMax10
¼"	1.70	34.75	0.456	11.58	SM10 316L EP End Cap 0.25	576-00001
⅜"	1.75	44.45	0.583	14.82	SM10 316L EP End Cap 0.375	576-00002
½"	1.75	44.45	0.583	14.82	SM10 316L EP End Cap 0.5	576-00003
¾"	1.75	44.45	0.583	14.82	SM10 316L EP End Cap 0.75	576-00004
1"	1.75	44.45	0.583	14.82	SM10 316L EP End Cap 1.0	576-00005
1 ½"	2.00	50.80	0.667	16.93	SM10 316L EP End Cap 1.5	576-00006
2"	2.00	50.80	0.667	16.93	SM10 316L EP End Cap 2.0	576-00007
2 ½"	2.00	50.80	0.667	16.93	SM10 316L EP End Cap 2.5	576-00008
3"	2.00	50.80	0.667	16.93	SM10 316L EP End Cap 3.0	576-00009
4"	2.50	63.50	0.833	21.17	SM10 316L EP End Cap 4.0	576-00010
6"	3.15	80.00	2.625	66.67	SM10 316L EP End Cap 6.0	576-00011

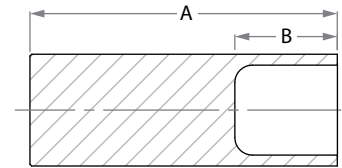

EL90 - Elbow 90° - EP (Electropolish)

O.D. Size Inch	Dimensions				Name	Catalog # 316L
	A inch	A mm	R inch	R mm		
					SciMax 10	
½"	3.000	76.20	1.130	28.60	SM10316LEPEL90-.5	580-00029
¾"	3.000	76.20	1.130	28.60	SM10316LEPEL90-.75	580-00030
1"	3.000	76.20	1.500	38.10	SM10316LEPEL90-1.0	580-00031
1 ½"	3.750	95.30	2.250	57.20	SM10316LEPEL90-1.5	580-00032
2"	4.750	120.70	3.000	76.20	SM10316LEPEL90-2.0	580-00033
2 ½"	5.500	139.70	3.750	95.25	SM10316LEPEL90-2.5	580-00034
3"	6.250	158.80	4.500	114.30	SM10316LEPEL90-3.0	580-00035
4"	8.000	203.20	6.000	152.40	SM10316LEPEL90-4.0	580-00036
6"	11.500	292.10	9.000	228.60	SM10316LEPEL90-6.0	580-00037

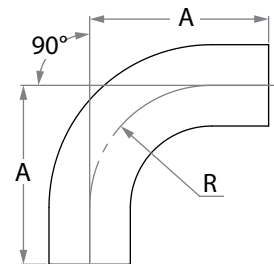

EL45 - Elbow 45° - EP (Electropolish)

O.D. Size Inch	Dimensions				Name	Catalog # 316L
	A inch	A mm	R inch	R mm		
					SciMax 10	
½"	2.250	57.20	1.130	28.60	SM10316LEPEL45-.5	580-00040
¾"	2.250	57.20	1.130	28.60	SM10316LEPEL45-.75	580-00041
1"	2.250	57.20	1.500	38.10	SM10316LEPEL45-1.0	580-00026
1 ½"	2.500	63.50	2.250	57.20	SM10316LEPEL45-1.5	580-00043
2"	3.000	76.20	3.000	76.20	SM10316LEPEL45-2.0	580-00044
2 ½"	3.375	85.70	3.750	95.25	SM10316LEPEL45-2.5	580-00045
3"	3.625	92.10	4.500	114.30	SM10316LEPEL45-3.0	580-00046
4"	4.500	114.30	6.000	152.40	SM10316LEPEL45-4.0	580-00048
6"	6.250	158.80	9.000	228.60	SM10316LEPEL45-6.0	580-00047

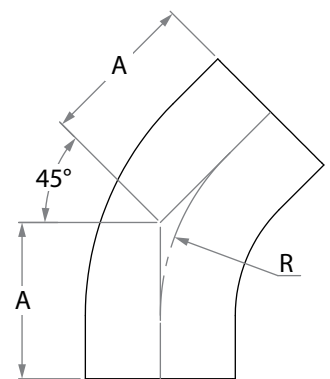

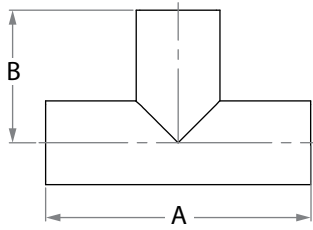

ETEE - Equal Tee - EP (Electropolish)

O.D. Size Inch	Dimensions				Name	Catalog # 316L SciMax 10
	A inch	A mm	B inch	B mm		
1/2"	3.750	95.25	1.875	47.60	SM10316LEPETEE-.5	579-00062
3/4"	4.000	101.60	2.000	50.80	SM10316LEPETEE-.75	579-00065
1"	4.250	108.00	2.125	54.00	SM10316LEPETEE-1.0	579-00069
1 1/2"	4.750	120.60	2.375	60.30	SM10316LEPETEE-1.5	579-00074
2"	5.750	146.00	2.875	73.00	SM10316LEPETEE-2.0	579-00080
2 1/2"	6.250	158.75	3.125	79.40	SM10316LEPETEE-2.5	579-00087
3"	6.750	171.40	3.375	85.70	SM10316LEPETEE-3.0	579-00095
4"	8.250	209.60	4.125	104.80	SM10316LEPETEE-4.0	579-00102
6"	11.250	285.80	5.625	142.90	SM10316LEPETEE-6.0	579-00110

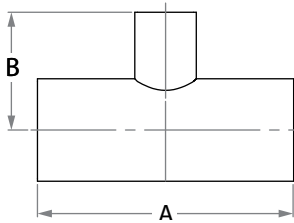

RTEE - Reducing Tee - EP (Electropolish)

O.D. Size Inch	Dimensions				Name	Catalog # 316L SciMax 10
	A inch	A mm	B inch	B mm		
1/2" x 3/8"	3.750	95.30	1.875	47.65	SM10316LEPRTEE-.5X.375	579-00064
3/4" x 1/4"	4.000	101.60	2.000	50.80	SM10316LEPRTEE-.75X.25	579-00066
3/4" x 3/8"	4.000	101.60	2.000	50.80	SM10316LEPRTEE-.75X.375	579-00067
3/4" x 1/2"	4.000	101.60	2.000	50.80	SM10316LEPRTEE-.75X.5	579-00068
1" x 1/4"	4.250	108.00	2.125	54.00	SM10316LEPRTEE-1.0X.25	579-00070
1" x 3/8"	4.250	108.00	2.125	54.00	SM10316LEPRTEE-1.0X.375	579-00071
1" x 1/2"	4.250	108.00	2.125	54.00	SM10316LEPRTEE-1.0X.5	579-00072
1" x 3/4"	4.250	108.00	2.125	54.00	SM10316LEPRTEE-1.0X.75	579-00073
1 1/2" x 1/4"	4.750	120.70	2.375	60.30	SM10316LEPRTEE-1.5X.25	579-00075
1 1/2" x 3/8"	4.750	120.70	2.375	60.30	SM10316LEPRTEE-1.5X.375	579-00076
1 1/2" x 1/2"	4.750	120.70	2.375	60.30	SM10316LEPRTEE-1.5X.5	579-00077
1 1/2" x 3/4"	4.750	120.70	2.375	60.30	SM10316LEPRTEE-1.5X.75	579-00078
1 1/2" x 1"	4.750	120.70	2.375	60.30	SM10316LEPRTEE-1.5X1.0	579-00079

RTEE - Reducing Tee - EP (Electropolish)

O.D. Size Inch	Dimensions				Name	Catalog # 316L
	A inch	A mm	B inch	B mm		
2" x 1/2"	5.750	146.00	2.625	66.70	SM10316LEPRTEE-2.0X.5	579-00083
2" x 3/4"	5.750	146.00	2.625	66.70	SM10316LEPRTEE-2.0X.75	579-00084
2" x 1"	5.750	146.00	2.625	66.70	SM10316LEPRTEE-2.0X1.0	579-00085
2" x 1 1/2"	5.750	146.00	2.625	66.70	SM10316LEPRTEE-2.0X1.5	579-00086
2 1/2" x 1/2"	6.250	158.80	2.875	73.00	SM10316LEPRTEE-2.5X.5	579-00090
2 1/2" x 3/4"	6.250	158.80	2.875	73.00	SM10316LEPRTEE-2.5X.75	579-00091
2 1/2" x 1"	6.250	158.80	2.875	73.00	SM10316LEPRTEE-2.5X1.0	579-00092
2 1/2" x 1 1/2"	6.250	158.80	2.875	73.00	SM10316LEPRTEE-2.5X1.5	579-00093
2 1/2" x 2"	6.250	158.80	2.875	73.00	SM10316LEPRTEE-2.5X2.0	579-00094
3" x 1/2"	6.750	171.50	3.125	79.40	SM10316LEPRTEE-3.0X.5	579-00096
3" x 3/4"	6.750	171.50	3.125	79.40	SM10316LEPRTEE-3.0X.75	579-00097
3" x 1"	6.750	171.50	3.125	79.40	SM10316LEPRTEE-3.0X1.0	579-00098
3" x 1 1/2"	6.750	171.50	3.125	79.40	SM10316LEPRTEE-3.0X1.5	579-00099
3" x 2"	6.750	171.50	3.125	79.40	SM10316LEPRTEE-3.0X2.0	579-00100
3" x 2 1/2"	6.750	171.50	3.125	79.40	SM10316LEPRTEE-3.0X2.5	579-00101
4" x 1/2"	8.250	209.60	3.625	92.10	SM10316LEPRTEE-4.0X.5	579-00103
4" x 3/4"	8.250	209.60	3.625	92.10	SM10316LEPRTEE-4.0X.75	579-00104
4" x 1"	8.250	209.60	3.625	92.10	SM10316LEPRTEE-4.0X1.0	579-00105
4" x 1 1/2"	8.250	209.60	3.625	92.10	SM10316LEPRTEE-4.0X1.5	579-00106
4" x 2"	8.250	209.60	3.875	98.40	SM10316LEPRTEE-4.0X2.0	579-00107
4" x 2 1/2"	8.250	209.60	3.875	98.40	SM10316LEPRTEE-4.0X2.5	579-00108
4" x 3"	8.250	209.60	3.875	98.40	SM10316LEPRTEE-4.0X3.0	579-00109
6" x 1/2"	11.250	285.80	4.875	123.80	SM10316LEPRTEE-6.0X.5	579-00111
6" x 3/4"	11.250	285.80	4.875	123.80	SM10316LEPRTEE-6.0X.75	579-00112
6" x 1"	11.250	285.80	4.875	123.80	SM10316LEPRTEE-6.0X1.0	579-00113
6" x 1/4"	11.25	285.8	4.625	117.5	SM10316LEPRTEE-6.0X.25	579-00441
6" x 1/2"	11.25	285.8	4.625	117.5	SM10316LEPRTEE-6.0X.5	579-00111
6" x 3/4"	11.25	285.8	4.625	117.5	SM10316LEPRTEE-6.0X.75	579-00112
6" x 1"	11.25	285.8	4.625	117.5	SM10316LEPRTEE-6.0X1.0	579-00564-SL
6" x 1"	11.25	285.8	4.625	117.5	SM10316LEPRTEE-6.0X1.0	579-00113
6" x 1 1/2"	11.25	285.8	4.625	117.5	SM10316LEPRTEE-6.0X1.5	579-00114
6" x 2"	11.25	285.8	4.875	123.8	SM10316LEPRTEE-6.0X2.0	579-00115
6" x 2 1/2"	11.25	285.8	4.875	123.8	SM10316LEPRTEE-6.0X2.5	579-00116
6" x 3"	11.25	285.8	4.875	123.8	SM10316LEPRTEE-6.0X3.0	579-00117
6" x 4"	11.25	285.8	5.125	130.2	SM10316LEPRTEE-6.0X4.0	579-00118

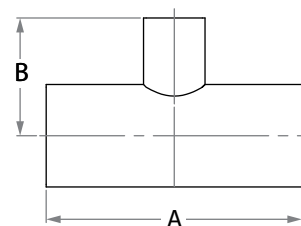

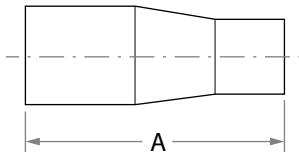

CORD - Concentric Reducer - EP

O.D. Size Inch	Dimensions		Name	Catalog # 316L
	A inch	A mm		
3/4" x 1/2"	1.875	47.63	SM10316LEPCORD-.75X.5	578-00037
1" x 1/2"	2.125	53.97	SM10316LEPCORD-1.0X.5	578-00040
1" x 3/4"	2.125	53.97	SM10316LEPCORD-1.0X.75	578-00041
1 1/2 x 1/2"	2.250	57.15	SM10316LEPCORD-1.5X.5	578-00044
1 1/2 x 3/4"	2.250	57.15	SM10316LEPCORD-1.5X.75	578-00045
1 1/2" x 1"	2.250	57.15	SM10316LEPCORD-1.5X1.0	578-00046
2" x 1/2"	2.750	69.85	SM10316LEPCORD-2.0X.5	578-00049
2" x 3/4"	2.750	69.85	SM10316LEPCORD-2.0X.75	578-00050
2" x 1"	2.750	69.85	SM10316LEPCORD-2.0X1.0	578-00051
2" x 1 1/2"	2.750	69.85	SM10316LEPCORD-2.0X1.5	578-00052
2 1/2" x 1/2"	3.500	88.90	SM10316LEPCORD-2.5X.5	578-00053
2 1/2" x 3/4"	3.500	88.90	SM10316LEPCORD-2.5X.75	578-00054
2 1/2" x 1"	3.500	88.90	SM10316LEPCORD-2.5X1.0	578-00055
2 1/2" x 1 1/2"	3.500	88.90	SM10316LEPCORD-2.5X1.5	578-00056
2 1/2" x 2"	3.500	88.90	SM10316LEPCORD-2.5X2.0	578-00057
3" x 1/2"	4.250	108.00	SM10316LEPCORD-3.0X.5	578-00058
3" x 3/4"	4.250	108.00	SM10316LEPCORD-3.0X.75	578-00059
3" x 1"	4.250	108.00	SM10316LEPCORD-3.0X1.0	578-00060
3" x 1 1/2"	4.250	108.00	SM10316LEPCORD-3.0X1.5	578-00061
3" x 2"	4.250	108.00	SM10316LEPCORD-3.0X2.0	578-00062
3" x 2 1/2"	4.250	108.00	SM10316LEPCORD-3.0X2.5	578-00063
4" x 3/4"	5.000	127.00	SM10316LEPCORD-4.0X.75	578-00064
4" x 1"	5.000	127.00	SM10316LEPCORD-4.0X1.0	578-00065
4" x 1 1/2"	5.000	127.00	SM10316LEPCORD-4.0X1.5	578-00066
4" x 2"	5.000	127.00	SM10316LEPCORD-4.0X2.0	578-00067
4" x 2 1/2"	5.000	127.00	SM10316LEPCORD-4.0X2.5	578-00068
4" x 3"	5.000	127.00	SM10316LEPCORD-4.0X3.0	578-00069
6" x 1"	6.000	152.40	SM10316LEPCORD-6.0X1.0	578-00070
6" x 1 1/2"	6.000	152.40	SM10316LEPCORD-6.0X1.5	578-00071
6" x 2"	6.000	152.40	SM10316LEPCORD-6.0X2.0	578-00072
6" x 2 1/2"	6.000	152.40	SM10316LEPCORD-6.0X2.5	578-00073
6" x 3"	6.000	152.40	SM10316LEPCORD-6.0X3.0	578-00074
6" x 4"	6.000	152.40	SM10316LEPCORD-6.0X4.0	578-00075

MTR - Material Test Report

The MTR is the reference document for the entire history of the production processes and the raw materials used to make the SCiMax component.

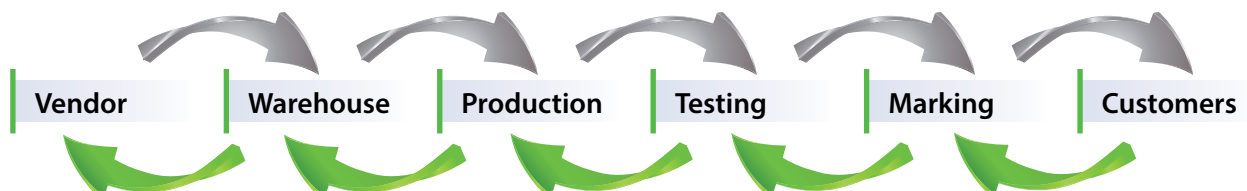

The MTR document is easily generated on - line via egmo.co.il using only the job number as input. The job number is the product identification number which represents all processes and raw materials related to the specific item.

ON - LINE MTR

ON - LINE MTR

Please, enter job/certificate number:



The MTR format provides the following information:

- Part number, part description and job number
- Material type
- Heat Number per each component describing the fitting and its associated properties:
 - Tube dimensions and standards
 - Chemical composition
 - Mechanical properties
 - Visual, dimensional, corrosion, EDDY current testing, flaring and flattening, PMI Test
- Certificate of Compliance

NEUMO EHRENBERG GROUP

GLOBAL LOCATIONS



NEUMO GmbH+Co. KG (D)
Tel: +49 (0) 7043 36 0
Fax: +49 (0) 7043 36 179
E - Mail: info@neumo.de
www.neumo.de
GERMANY



VNE Corporation
Tel: +1 800 356 1111
+1 608 756 4930
Fax: +1 608 756 3643
E - Mail: stainless@vncorp.com
www.vnestainless.com
U.S.A



EGMO Ltd.
Tel: +972 (0) 4 9855 176
+972 (0) 4 9855 111
Fax: +972 (0) 4 9855 175
E - Mail: salese@egmo.co.il
www.egmo.co.il
ISRAEL



NEUMO - EGMO Spain S.L
Tel: +34 977 524 914
Fax: +34 977 524 898
E - Mail: neumo-es@neumo-es.com
www.neumo-es.com
SPAIN



HPT Inc.
Tel: +845.452.1103
+800.284.4478
E - Mail: sales@hptinc.com
<http://www.hptinc.com/>
U.S.A



Herrli AG
Tel: +41 (0) 31 750 12 11
Fax: +41 (0) 31 750 12 00
E - Mail: info@herrli.net
www.herrli.net
SWITZERLAND



NEUMO Polska Sp. z.o.o
Tel: +48 (0) 46 833 4306
Fax: +48 (0) 46 832 5626
E - Mail: neumo@neumo.pl
POLAND



NEUMO Turkey
Tel: +90 (212) 875 01 41
Fax: +90 (212) 875 23 13
E - Mail: info@neumo.com.tr
www.neumo.com.tr
TURKEY



NEUMO Budapest Kft
Tel: +36 (1) 3174177
+36 (1) 3185982
Fax: +36 (1) 266 8765
E - Mail: neumo@neumo.hu
www.neumo.hu
HUNGARY



NEUMO LLC
Tel: +84 908475382
E-Mail: Minh.Vietnam@neumo.de
www.awh.eu
VIETNAM



NEUMO - VARGUS (Shanghai)
Trading Co., Ltd
Tel: +86 (21) 54177932
Fax: +86 (21) 54178190
E - Mail: info@neumo.com.cn
CHINA



NEUMO UK Ltd.
Tel: +44 (0) 1952 583 999
Fax: +44 (0) 1952 583 958
E - Mail: stainless@neumo.co.uk
www.neumo.co.uk
UNITED KINGDOM



AWH Armaturenwerke (D)
Hötensleben GmbH
Tel: +49 (0) 39405 92 0
Fax: +49 (0) 39405 92 111
E - Mail: info@awh.de
www.awh.de



EGMO Ireland
Tel: +353 (0)21 4975540
Cel: +353 (0)87 2330469
E-Mail: dosullivan@flowsolutions.ie
www.egmo.co.il
IRELAND



Damstahl a/s (Denmark)
Tel: +45 (0) 8794 4000
Fax: +45 (0) 8794 4150
E - Mail: ds@damstahl.com
www.damstahl.dk
DENMARK

Damstahl GmbH (D)
Tel: +49 (0) 2173 797 0
Fax: +49 (0) 2173 797 274
E - Mail: ds@damstahl.de
www.damstahl.de



Damstahl a/s Oslo (N)
Tel: +47 5615 1570
Fax: +47 5615 1571
E - Mail: dano@damstahl.com
www.damstahl.no
NORWAY



Damstahl a/b (Sweden)
Tel: +46 87 61 71 00
Fax: +46 87 61 14 05
www.damstahl.se
SWEDEN

Gebr. Rieger GmbH+Co. KG (D)
Tel: +49 (0) 7361 5702 0
Fax: +49 (0) 7361 5702 51
E - Mail: info@rr-rieger.de
www.rr-rieger.de
GERMANY